

Service Manual

OPTIMUS PRO Split



CONTENTS

- Part 1 General Information..... 3
- Part 2 Component Layout and Refrigerant Circuits 5
- Part 3 Control 15
- Part 4 Diagnosis and Troubleshooting..... 29

Part 1


General Information


1 Product lineup 4

OPTIMUS PRO Split

1 Product lineup

1.1 Outdoor unit

Model	HOP4WODU	HOP6WODU
Power Supply (V/Ph/Hz)	220-240/1 /50	220-240/1 /50
Appearance		

Model	HOP8WODU	HOP10WODU	HOP12WODU	HOP12WODU3	HOP14WODU	HOP14WODU3	HOP16WODU	HOP16WODU3
Power Supply (V/Ph/Hz)	220-240/1/50	220-240/1/50	220-240/1/50	380-415/3/50	220-240/1/50	380-415/3/50	220-240/1/50	380-415/3/50
Appearance								

1.2 Hydro module with water tank

Model	HOP100/190IDU(3)	HOP100/240IDU(3)	HOP160/240IDU3
Power Supply (V/Ph/Hz)	220-240/1 /50 380-415/3/50	220-240/1 /50 380-415/3/50	380-415/3/50
Compatible outdoor unit model	HOP4WODU HOP6WODU HOP8WODU HOP10WODU	HOP4WODU HOP6WODU HOP8WODU HOP10WODU	HOP12WODU HOP14WODU HOP16WODU HOP12WODU3 HOP14WODU3 HOP16WODU3
Appearance			

Part 2

Component Layout and Refrigerant Circuits

1 Layout of Functional Components..... 6

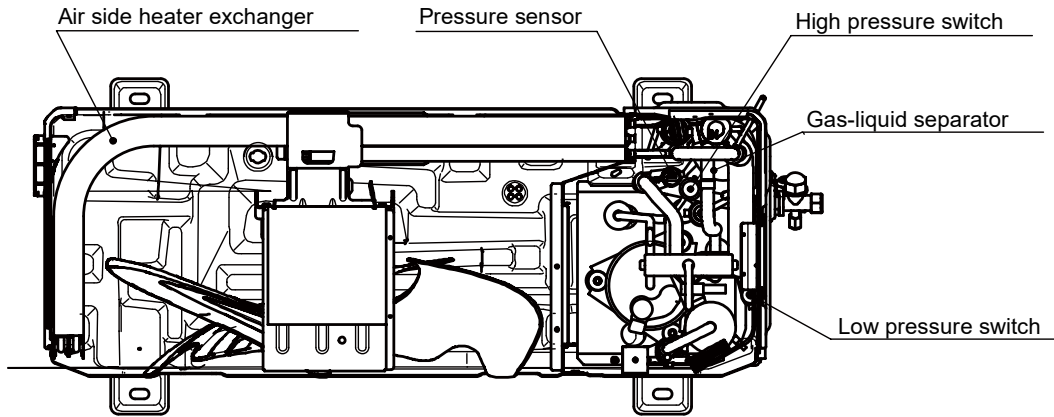
2 Piping Diagrams 11

OPTIMUS PRO Split

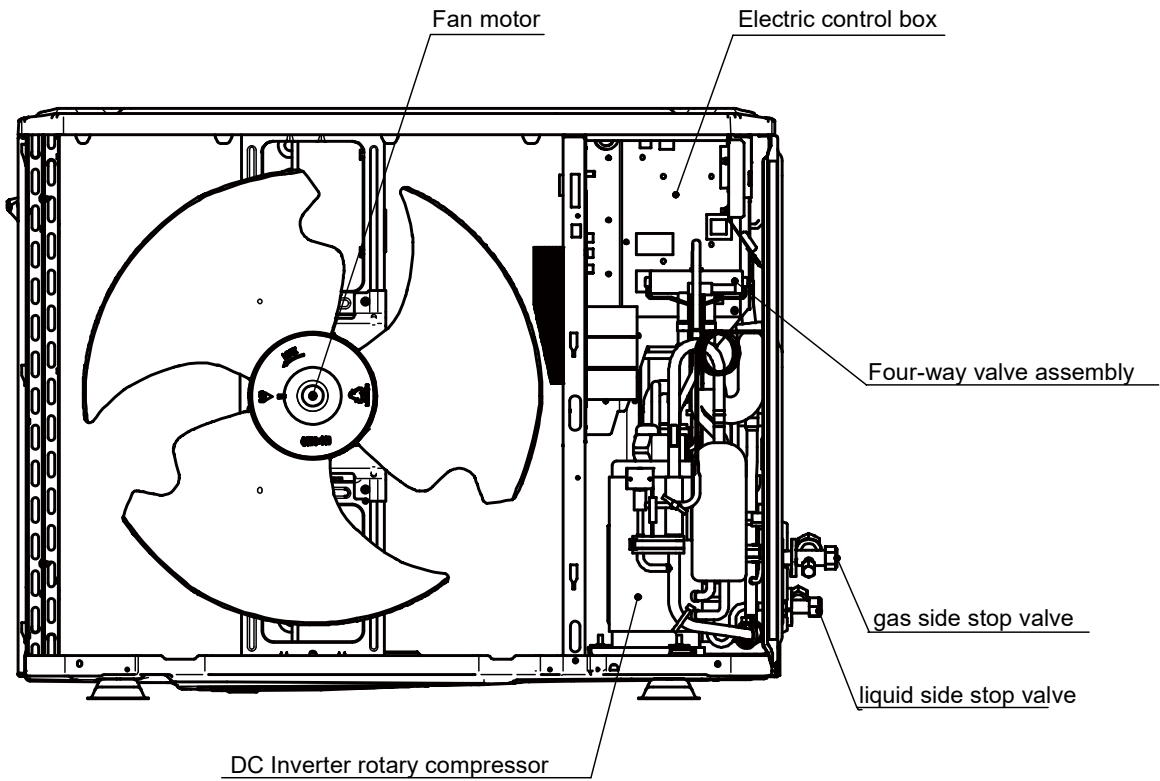
1 Layout of Functional Components

1.1 Outdoor Unit Layout HOP4WODU / HOP6WODU

Top view

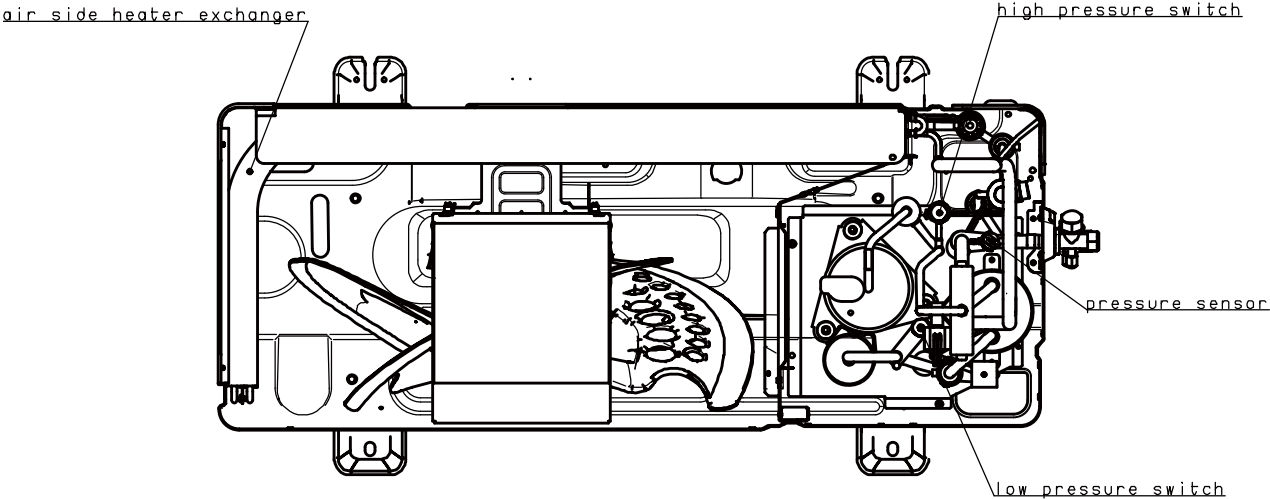


Front view

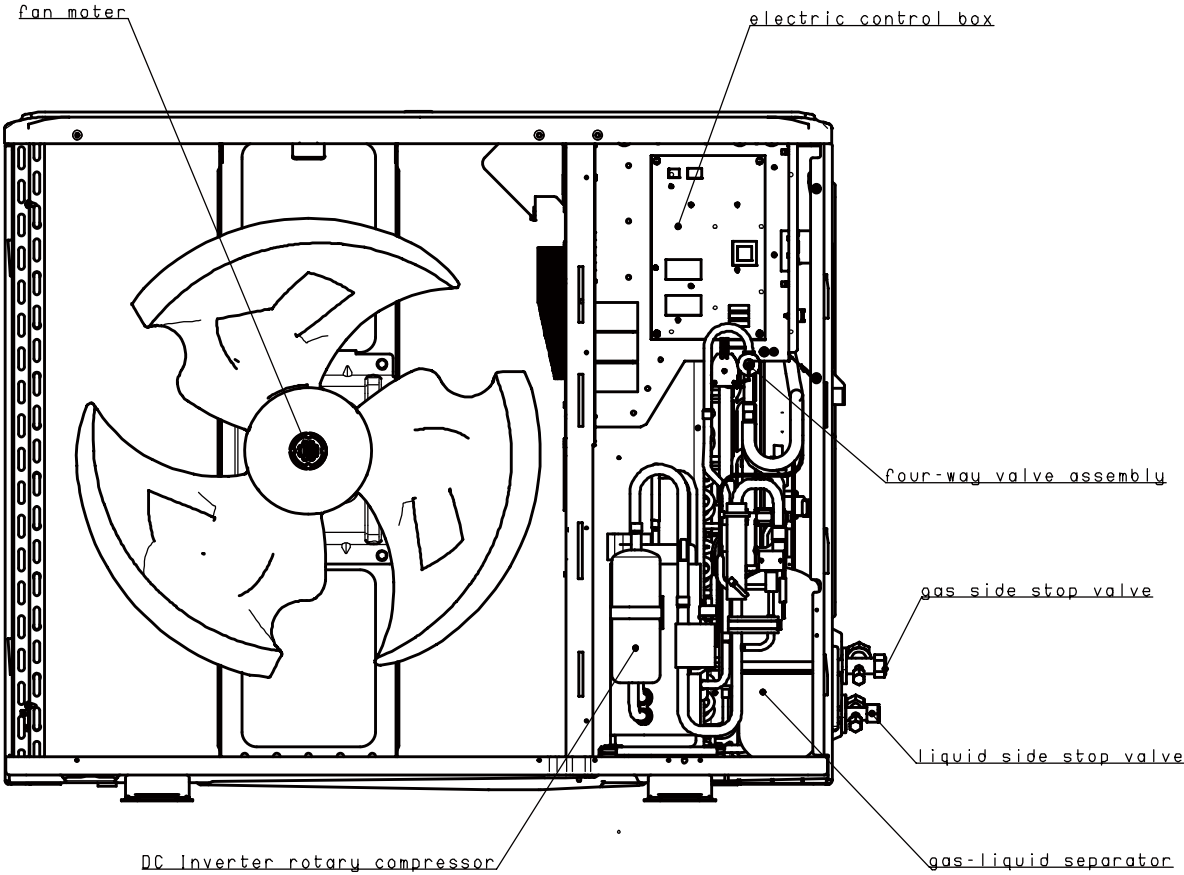


HOP8WODU / HOP10WODU

Top view



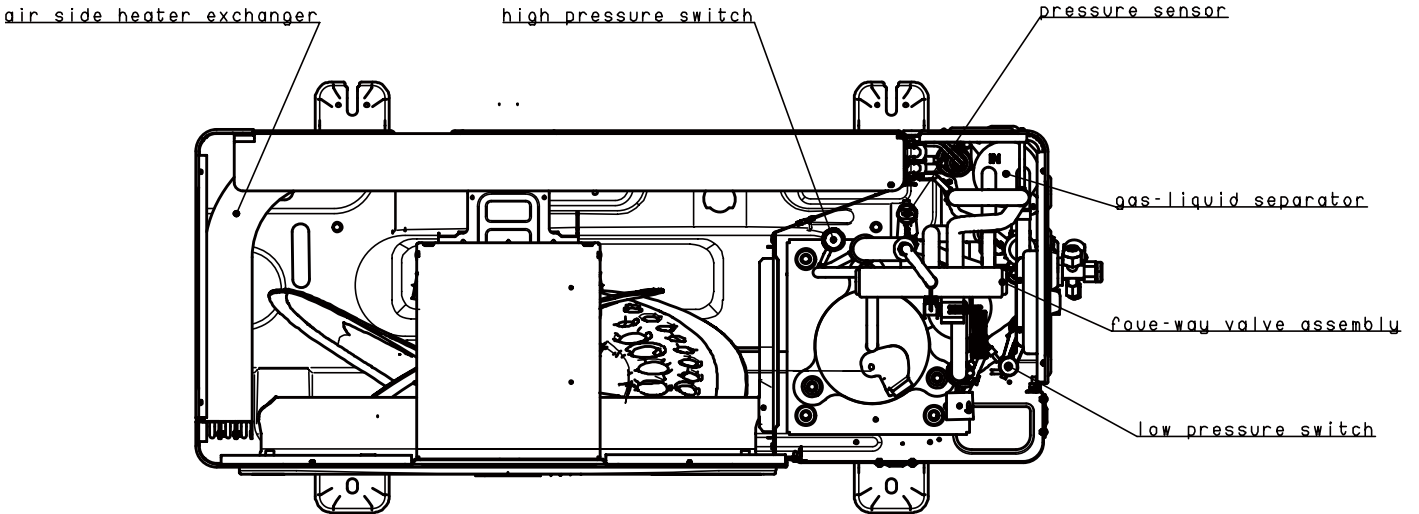
Front view



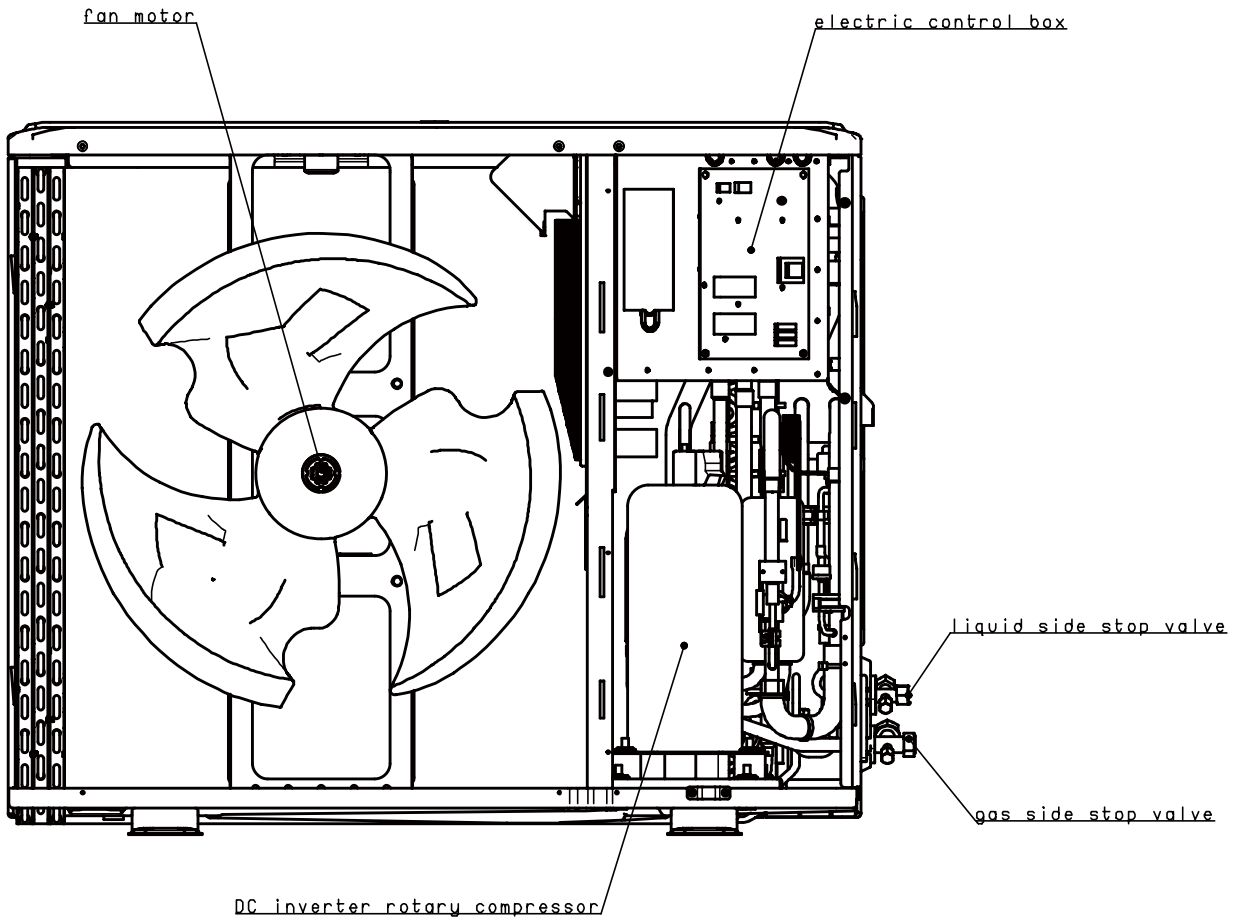
OPTIMUS PRO Split

HOP12WODU / HOP14WODU / HOP16WODU

Top view

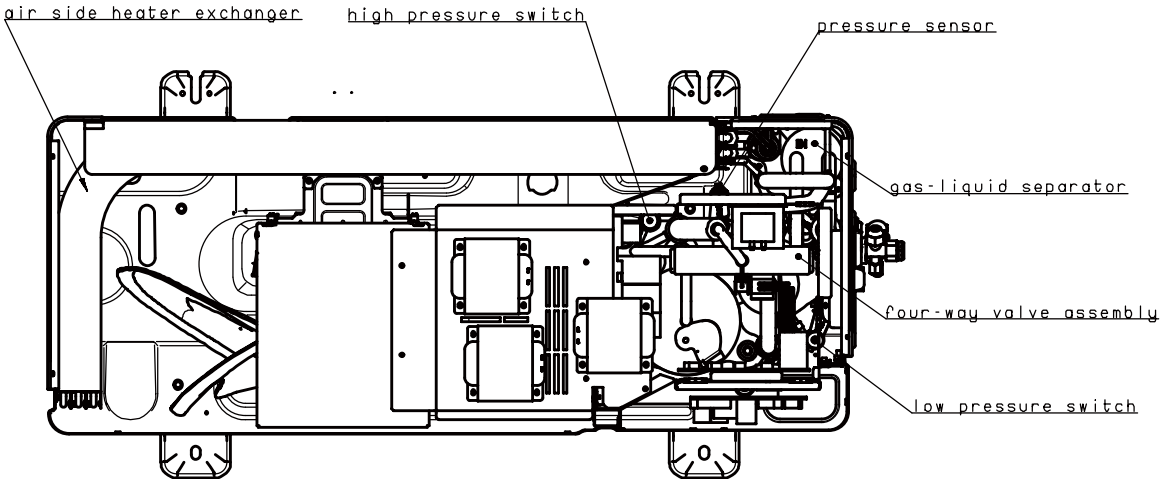


Front view

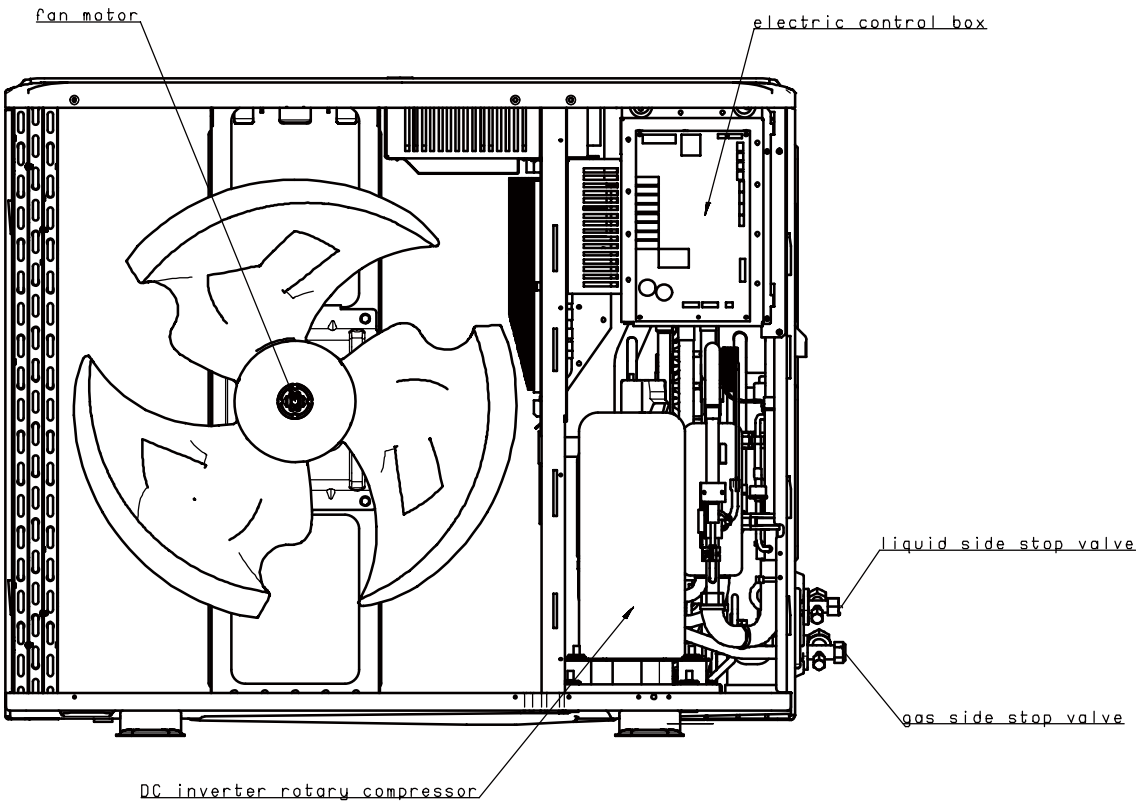


HOP12WODU3 / HOP14WODU3 / HOP16WODU3

Top view



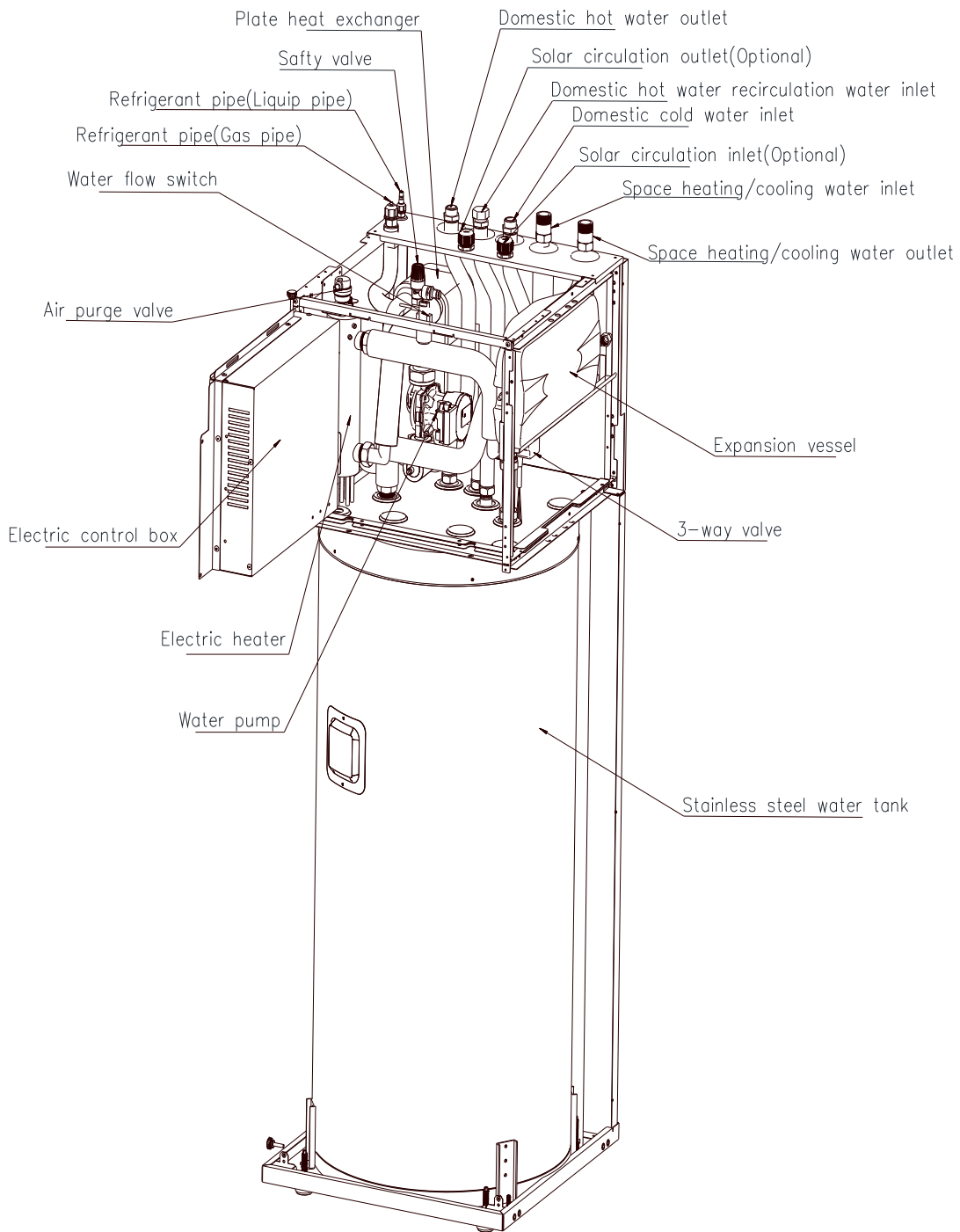
Front view



OPTIMUS PRO Split

1.2 Hydronic Box Layout

Oblique view



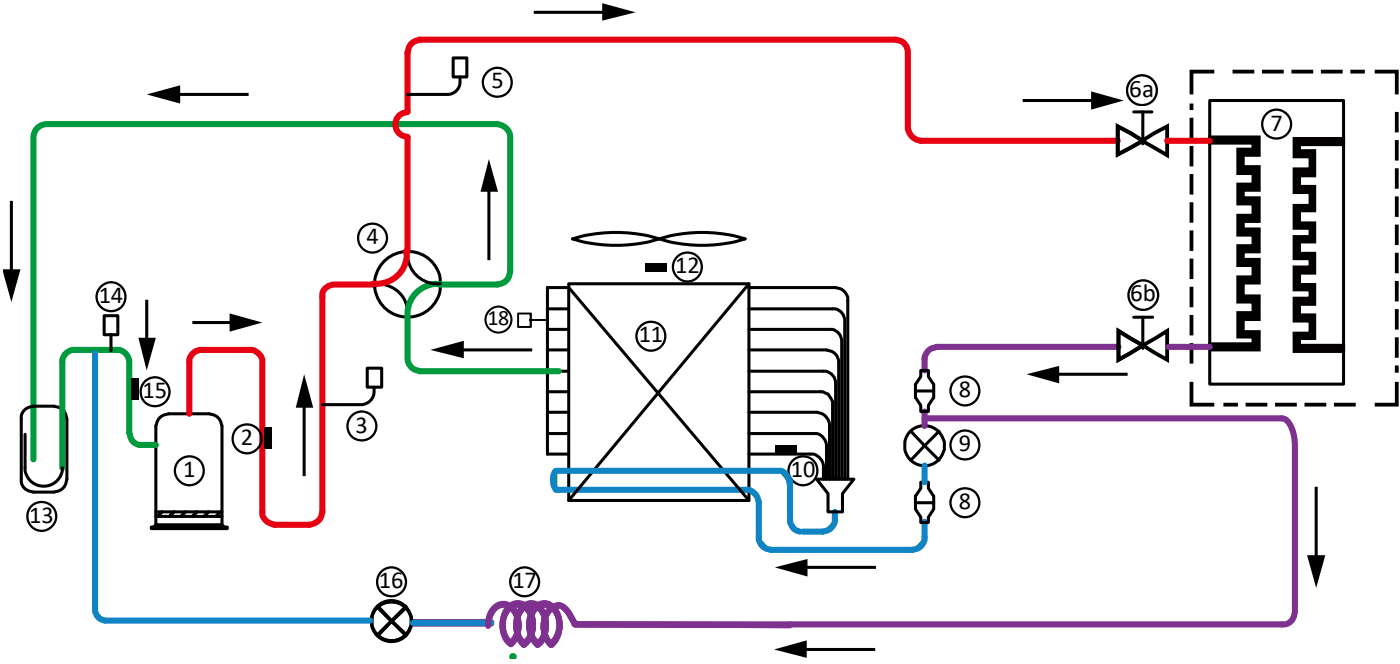
2 Piping Diagrams

2.1 Outdoor Unit Piping

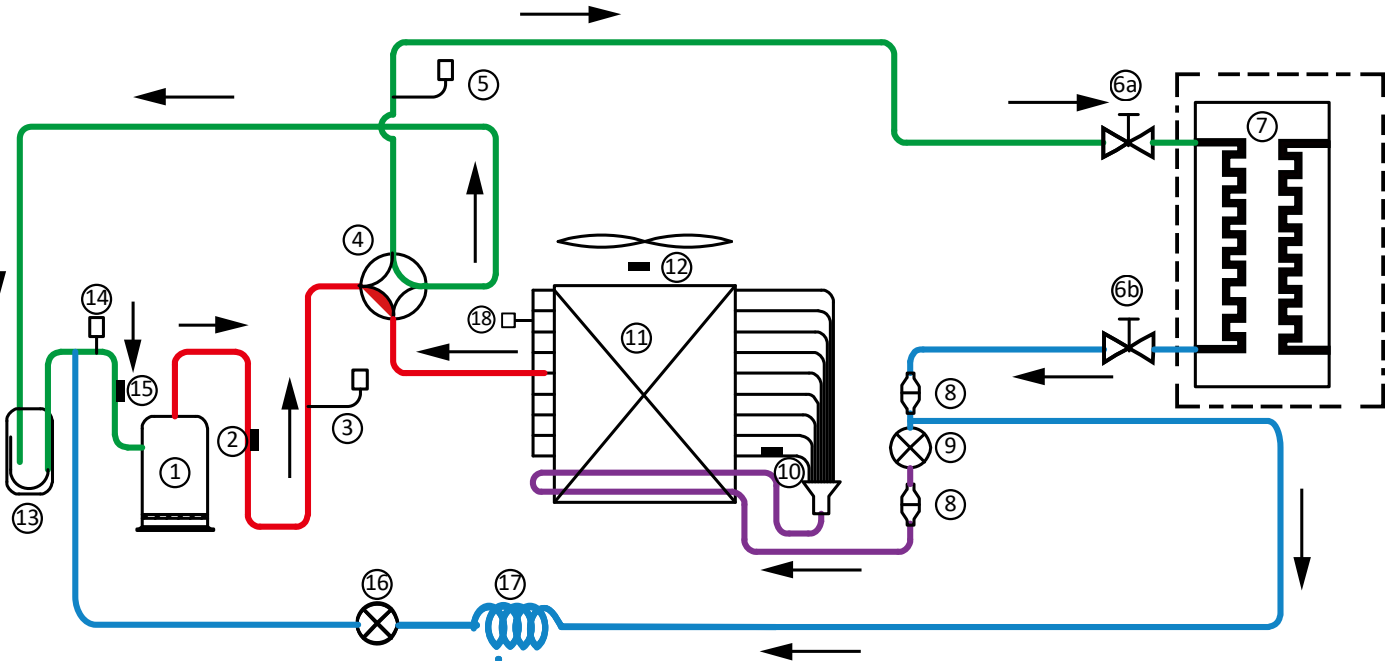
Refrigerant piping graphic example:

- High temperature, high pressure gas
- High temperature, high pressure liquid
- Low temperature, low pressure gas
- Low temperature, low pressure gas liquid mixture

Heating and DHW mode



Cooling mode



OPTIMUS PRO Split

Legend			
1	Compressor	10	Evaporation sensor in heating (Condenser sensor in cooling)
2	Discharge temperature sensor (Tp)	11	Air side heat exchanger
3	High Pressure Switch	12	Outdoor temperature sensor (T4)
4	4-way valve	13	Gas-liquid separator
5	Pressure sensor	14	Low Pressure Switch
6	Stop valve: 6a include Service port for 4~16kW models 6b include Service port for 8~16kW models	15	Suction temperature sensor (Th)
7	Plate heat exchanger	16	Single-way electromagnetic valve
8	Strainer	17	Capillary
9	Electronic expansion Valve	18	Lok ring

Key components:

Electronic expansion valve (EXV):

Controls refrigerant flow and reduces refrigerant pressure.

Four-way valve:

Controls refrigerant flow direction. Closed in cooling mode and open in heating mode. When closed, the air side heat exchanger functions as a condenser and water side heat exchanger functions as an evaporator; when open, the air side heat exchanger functions as an evaporator and water side heat exchanger function as a condenser.

High and low pressure switches:

Regulate refrigerant system pressure. When refrigerant system pressure rises above the upper limit or falls below the lower limit, the high or low pressure switches turn off, stopping the compressor.

Separator:

Separates liquid refrigerant from gas refrigerant to protect compressor from liquid hammering.

Service port:

Used for releasing refrigerant, adding refrigerant, connecting pressure meter.

Lok ring:

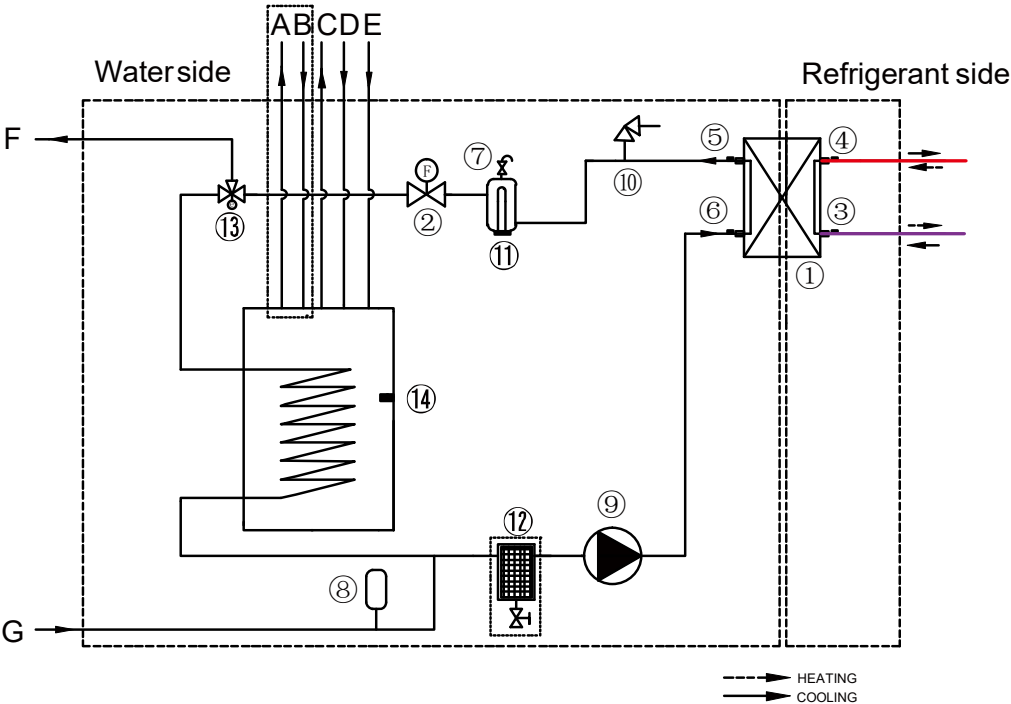
Used for sealing the refrigerant system in factory, which can not be used for aftersales service on site.

2.2 Hydronic box Piping

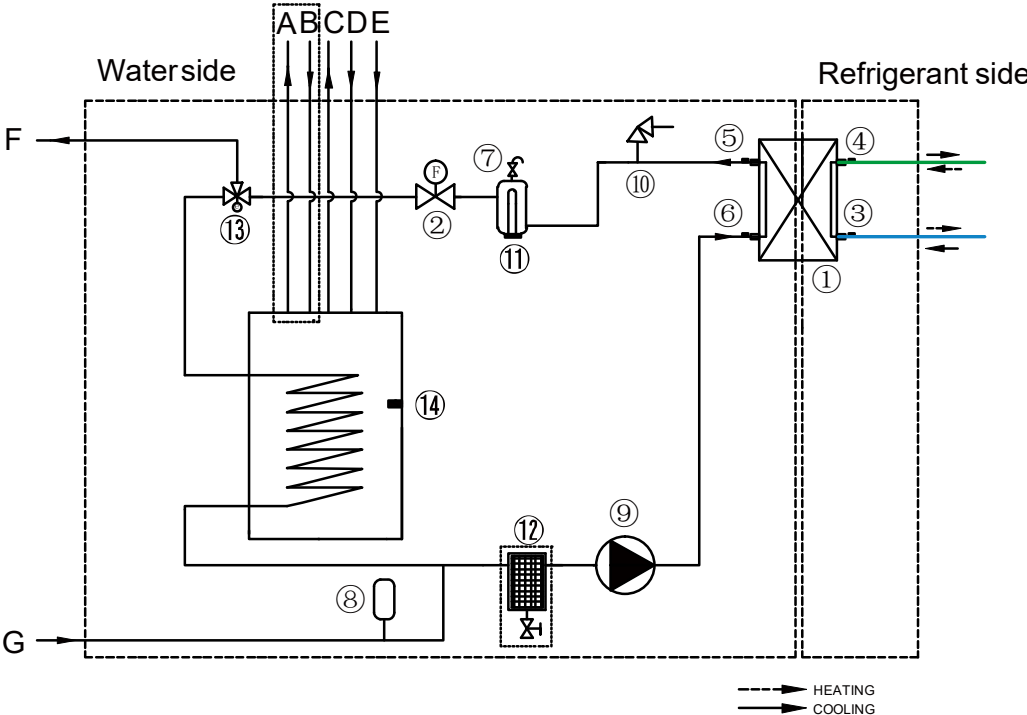
Refrigerant piping graphic example:

- High temperature, high pressure gas
- High temperature, high pressure liquid
- Low temperature, low pressure gas
- Low temperature, low pressure gas liquid mixture

Heating and DHW mode



Cooling mode



OPTIMUS PRO Split

Legend			
1	Water side heat exchanger	12	Magnetic separator(Optional)
2	Water flow switch	13	3-Way valve
3	Refrigerant liquid pipe temperature sensor (T2)	14	Domestic water tank temperature sensor (T5)
4	Refrigerant gas pipe temperature sensor (T2B)	A	Solar circulation outlet(Optional)
5	Water outlet temperature sensor (Tw_out)	B	Solar circulation inlet(Optional)
6	Water inlet temperature sensor (Tw_in)	C	Domestic cold water outlet
7	Automatic air purge valve	D	Domestic hot water recirculation inlet
8	Expansion vessel	E	Domestic cold water inlet
9	Water pump	F	Space heating/cooling water outlet
10	Pressure relief valve	G	Space heating/cooling water inlet
11	Backup heater		

Key components:

Air purge valve:

Automatically removes air from the water circuit.

Pressure relief valve:

Prevents excessive water pressure by opening at 43.5 psi (3 bar) and discharging water from the water circuit.

Expansion vessel:

Balances water system pressure. (Expansion vessel volume: 8L.)

Water flow switch:

Detects water flow rate to protect compressor and water pump in the event of insufficient water flow.

Backup electric heater:

Provides additional heating capacity when the heating capacity of the heat pump is insufficient due to very low outdoor temperature. Also protects the external water piping from freezing.

Water pump:

Circulates water in the water circuit.

3-way valve

Change the refrigerant circuit between DHW mode and heating/cooling mode.

Magnetic separator(Optional)

Absorb iron scrap impurities and deposit sediment to keep the water system clean.

Part 3

Control

1 Stop Operation	16
2 Standby Control	16
3 Startup Control	17
4 Normal Operation Control	20
5 Protection Control	21
6 Special Control.....	24

1 Stop Operation

The stop operation occurs for one of the following reasons:

1. Abnormal shutdown: in order to protect the compressors, if an abnormal state occurs the system makes a stop with thermo off operation and an error code is displayed on the outdoor unit PCB digital displays and on the user interface.
2. The system stops when the set temperature has been reached.

2 Standby Control

2.1 Crankcase Heater Control

The crankcase heater is used to prevent refrigerant from mixing with compressor oil when the compressors are stopped. The crankcase heater is controlled according to outdoor ambient temperature and the compressor on/off state. When the outdoor ambient temperature is above 8°C or the compressor is running, the crankcase heater is off; when the outdoor ambient temperature is at or below 8°C and either the compressor has been stopped for more than 3 hours or the unit has just been powered-on (either manually or when the power has returned following a power outage), the crankcase heater turns on.

2.2 Water Pump Control

When the outdoor unit is in standby, the internal and external circulator pumps run continuously.

3 Startup Control

3.1 Compressor Startup Delay Control

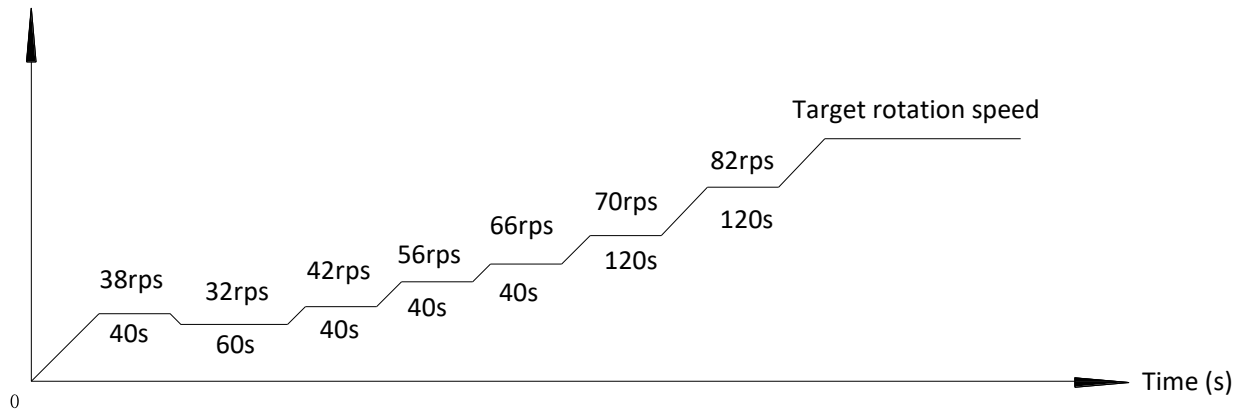
In initial startup control and in restart control (except in oil return operation and defrosting operation), compressor startup is delayed such that a minimum of the set re-start delay time has elapsed since the compressor stopped, in order to prevent frequent compressor on/off and to equalize the pressure within the refrigerant system. The compressor re-start delays for cooling and heating modes are set on the user interface. Refer to the OPTIMUS PRO Split Engineering Data Book Part 3, 8.5 "COOL MODE SETTING Menu" and Part 3, 8.6 "HEAT MODE SETTING Menu".

3.2 Compressor Startup Program

In initial startup control and in re-start control, compressor startup is controlled according to outdoor ambient temperature. Compressor startup follows one of two startup programs until the target rotation speed is reached.

HOP4(6)WODU compressor startup program¹ when ambient temperature is above 3°C

Compressor rotation speed (rps)

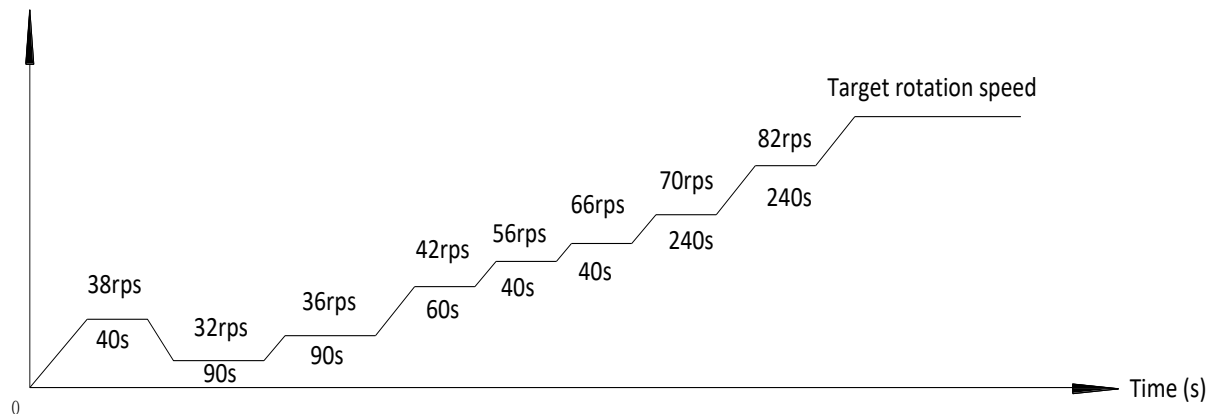


Notes:

- Once the first, 40-second stage of the program is complete, the program proceeds to the subsequent stages in a step-by-step fashion and exits when the target rotation speed has been reached.

HOP4(6)WODU compressor startup program¹ when ambient temperature is at or below 3°C

Compressor rotation speed (rps)

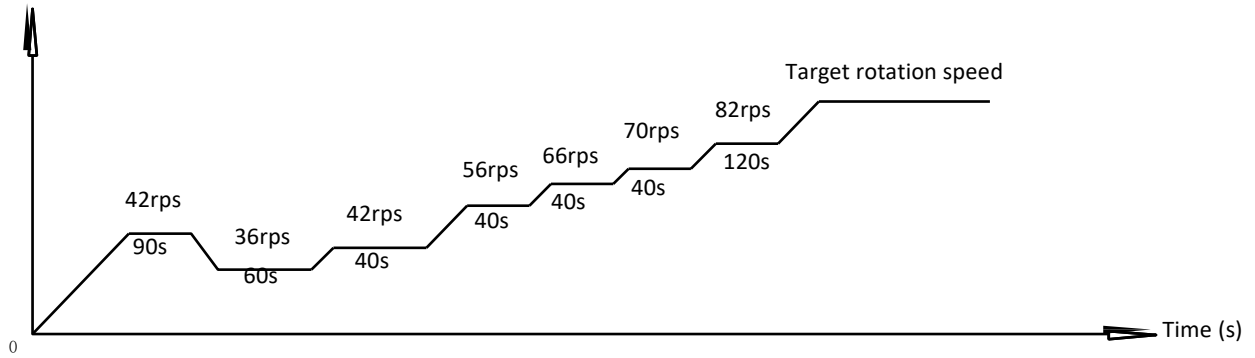


Notes:

- Once the first, 40-second stage of the program is complete, the program proceeds to the subsequent stages in a step-by-step fashion and exits when the target rotation speed has been reached.

OPTIMUS PRO Split

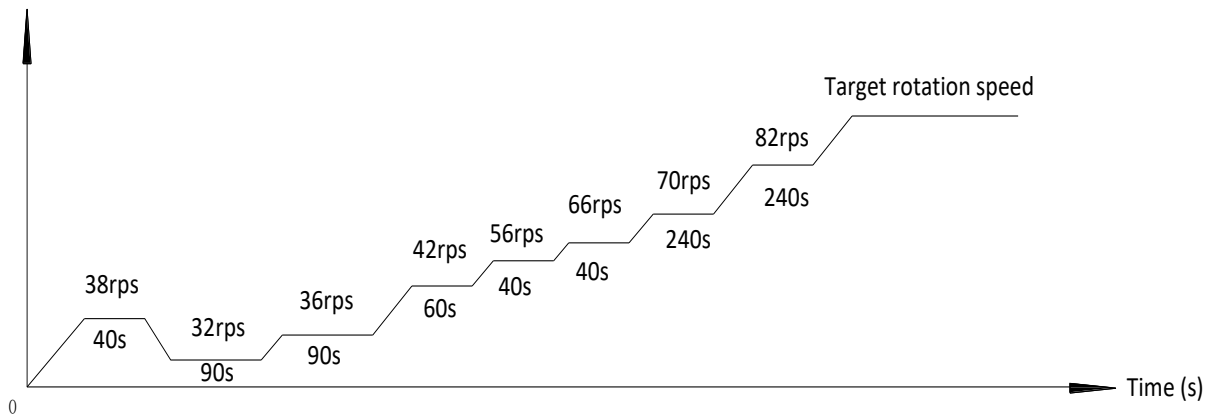
HOP8(10)WODU compressor startup program¹ when ambient temperature is above 11°C



- Notes:
- Once the first, 90-second stage of the program is complete, the program proceeds to the subsequent stages in a step-by-step fashion and exits when the target rotation speed has been reached.

HOP8(10)WODU compressor startup program¹ when ambient temperature is at or below 11°C

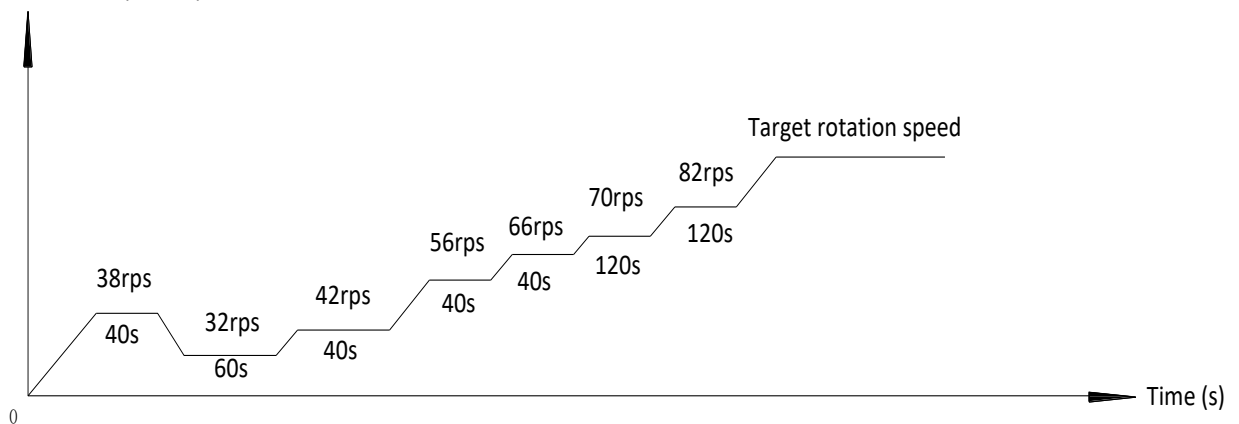
Compressor rotation speed (rpm)



- Notes:
- Once the first, 40-second stage of the program is complete, the program proceeds to the subsequent stages in a step-by-step fashion and exits when the target rotation speed has been reached.

MHA-V12(14,16)W/D2(R)N8-B compressor startup program¹ when ambient temperature is above 3°C

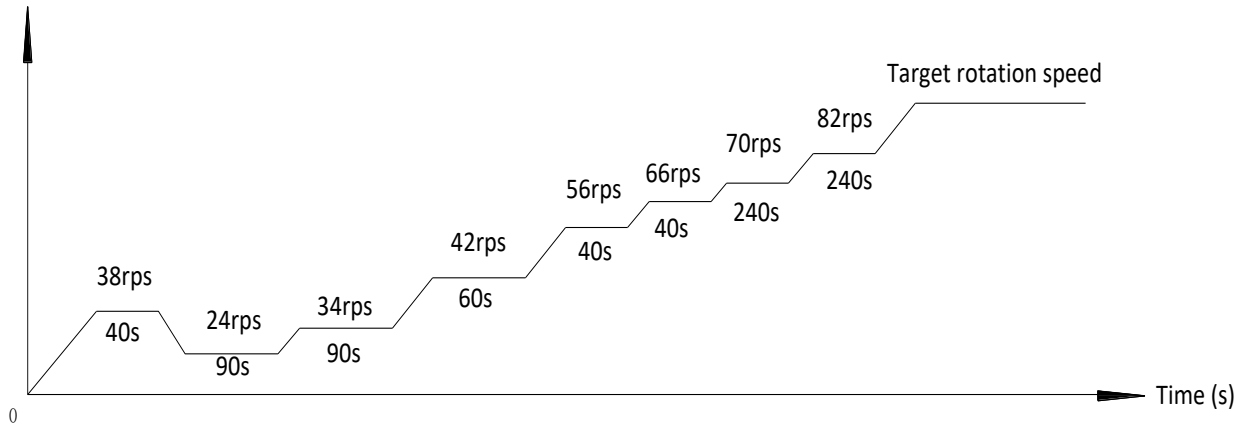
Compressor rotation speed (rpm)



- Notes:
- Once the first, 40-second stage of the program is complete, the program proceeds to the subsequent stages in a step-by-step fashion and exits when the target rotation speed has been reached.

MHA-V12(14,16)W/D2(R)N8-B compressor startup program¹ when ambient temperature is at or below 3°C

Compressor rotation speed (rps)



Notes:

- Once the first, 40-second stage of the program is complete, the program proceeds to the subsequent stages in a step-by-step fashion and exits when the target rotation speed has been reached.

3.3 Startup Control for Heating and Domestic Hot Water Operation

Component control during startup in heating and domestic hot water modes

Component	Wiring diagram label	4-16kW	Control functions and states
Inverter compressor	COMP	•	Compressor startup program selected according to ambient temperature ¹
DC fan motor	FAN	•	Fan run at maximum speed ²
Electronic expansion valve	EXV	•	Position (steps) from 0 (fully closed) to 480 (fully open), controlled according to outdoor ambient temperature, discharge temperature, suction superheat,
Four-way valve	4-WAY	•	On

Notes:

- Refer to Part 3, 3.2 "Compressor Startup Program".
- Refer to Table 3-4.3 in Part 3, 4.6 "Outdoor Fan Control".

3.4 Startup Control for Cooling Operation

Component control during startup in cooling mode

Component	Wiring diagram label	4-16kW	Control functions and states
Inverter compressor	COMP	•	Compressor startup program selected according to ambient temperature ¹
DC fan motor	FAN	•	Fan run at maximum speed ²
Electronic expansion valve	EXV	•	Position (steps) from 0 (fully closed) to 480 (fully open), controlled according to outdoor ambient temperature, discharge temperature, suction superheat
Four-way valve	4-WAY	•	Off

Notes:

- Refer to Part 3, 3.2 "Compressor Startup Program".
- Refer to Table 3-4.3 in Part 3, 4.6 "Outdoor Fan Control".

4 Normal Operation Control

4.1 Component Control during Normal Operation

Component control during heating and domestic hot water operations

Component	Wiring diagram label	4-16kW	Control functions and states
Inverter compressor	COMP	•	Controlled according to load requirement from hydronic system
DC fan motor	FAN	•	Controlled according to outdoor heat exchanger pipe temperature
Electronic expansion valve	EXV	•	Position (steps) from 0 (fully closed) to 480 (fully open), controlled according to discharge temperature, suction superheat and compressor speed
Four-way valve	4-WAY	•	On

Component control during cooling operation

Component	Wiring diagram label	4-16kW	Control functions and states
Inverter compressor	COMP	•	Controlled according to load requirement from hydronic system
DC fan motor	FAN	•	Controlled according to outdoor heat exchanger pipe temperature
Electronic expansion valve	EXV	•	Position (steps) from 0 (fully closed) to 480 (fully open), controlled according to discharge temperature, suction superheat and compressor speed
Four-way valve	4-WAY	•	Off

4.2 Compressor Output Control

The compressor rotation speed is controlled according to the load requirement. Before compressor startup, the OPTIMUS PRO Split outdoor unit determines the compressor target speed according to outdoor ambient temperature, leaving water set temperature and actual leaving water temperature and then runs the appropriate compressor startup program. Refer to Part 3, 3.2 “Compressor Startup Program”. Once the startup program is complete, the compressor runs at the target rotation speed.

4.3 Compressor Step Control

The running speed of six-pole compressors in rotations per second (rps) is one third of the frequency (in Hz) of the electrical input to the compressor motor. The frequency of the electrical input to the compressor motors can be altered at a rate of 1Hz per second.

4.4 Four-way Valve Control

The four-way valve is used to change the direction of refrigerant flow through the water side heat exchanger in order to switch between cooling and heating/DHW operations. Refer to Part 2, 3 “Refrigerant Flow Diagrams”. During heating and DHW operations, the four-way valve is on; during cooling and defrosting operations, the four-way valve is off.

4.5 Electronic Expansion Valve Control

The position of the electronic expansion valve (EXV) is controlled in steps from 0 (fully closed) to 480 (fully open).

- At power-on:
 - The EXV first closes fully, then moves to the standby position. After a few seconds the EXV moves to an initial running position, which is determined according to operating mode and outdoor ambient temperature. After a further a few minutes, the EXV is controlled according to suction superheat and discharge temperature. Once a further a few minutes have elapsed, the EXV is then controlled according to suction superheat, discharge temperature and compressor speed.
- When the outdoor unit is in standby:
 - The EXV is at standby position.
- When the outdoor unit stops:
 - The EXV first closes fully, then moves to the standby position.

4.6 Outdoor Fan Control

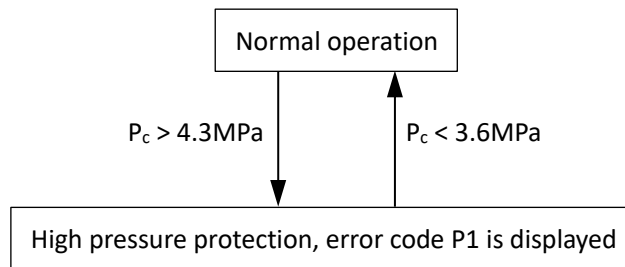
The speed of the outdoor unit fan is adjusted in steps, as shown in below:

Fan speed index	Fan speed (rpm)		
	4/6/8/10kW	12/14kW	16kW
W1	200	200	200
W2	250	250	250
W3	300	300	300
W4	350	350	350
W5	400	400	400
W6	450	450	450
W7	500	500	500
W8	530	550	550
W9	550	580	600
W10	580	610	650
W11	600	630	700
W12	600	650	730

5 Protection Control

5.1 High Pressure Protection Control

This control protects the refrigerant system from abnormally high pressure and protects the compressor from transient spikes in pressure.



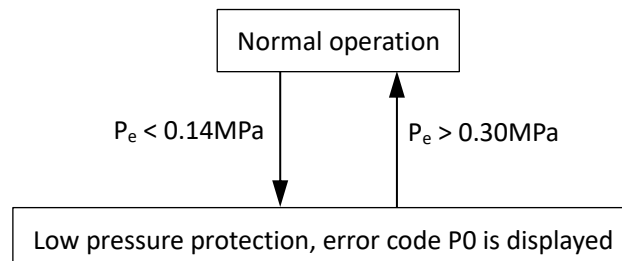
Notes:

1. Pc: Discharge pressure

When the discharge pressure rises above 4.3MPa the system displays P1 protection and the unit stops running. When the discharge pressure drops below 3.6MPa, the compressor enters re-start control.

5.2 Low Pressure Protection Control

This control protects the refrigerant system from abnormally low pressure and protects the compressor from transient drops in pressure.



Notes:

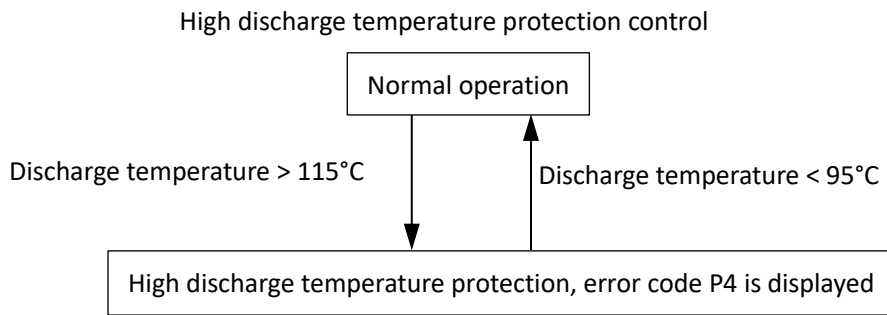
1. Pe: Suction pressure

When the suction pressure drops below 0.14MPa the system displays P0 protection and the unit stops running. When the suction pressure rises above 0.3MPa, the compressor enters re-start control.

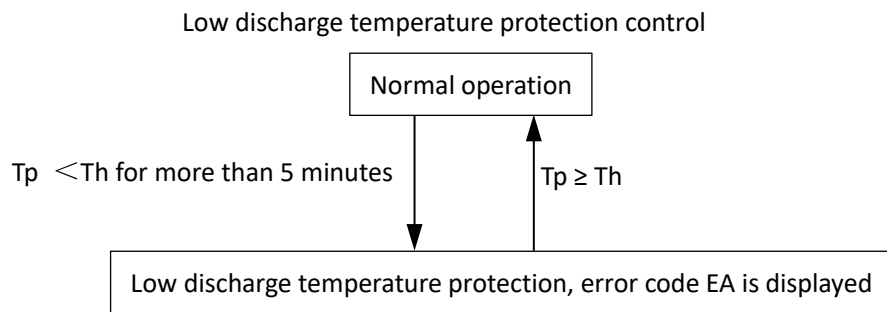
OPTIMUS PRO Split

5.3 Discharge Temperature Protection Control

This control protects the compressor from abnormally high temperatures and transient spikes in temperature.



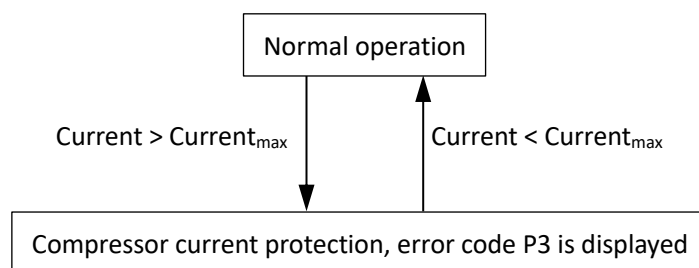
When the discharge temperature rises above 115°C the system displays P4 protection and the unit stops running. When the discharge temperature drops below 95°C, the compressor enters re-start control.



When the discharge temperature is lower than suction temperature for more than 5 minutes, the system displays EA protection and the unit stops running. When the discharge temperature is higher than suction temperature, the compressor enters re-start control.

5.4 Compressor Current Protection Control

This control protects the compressor from abnormally high currents.



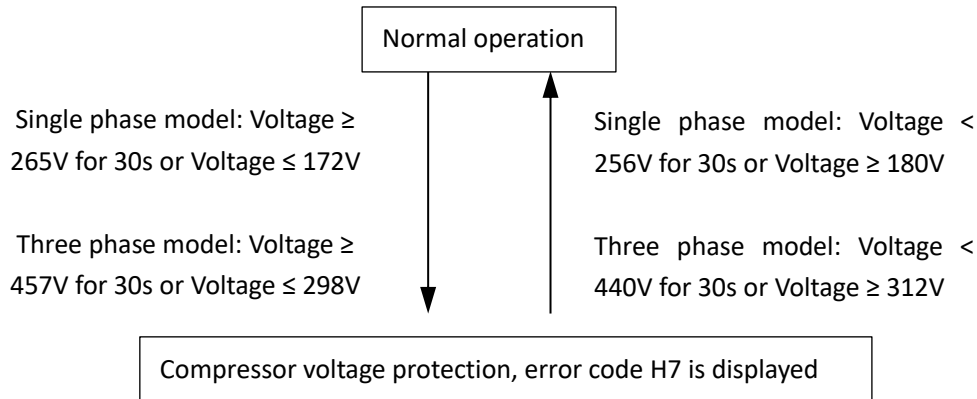
Current limitation for compressors

Model name	HOP4(6)WODU	HOP8(10)WODU	HOP12(14,16)WODU	HOP12(14,16)WODU3
Current _{max}	18A	19A	30A	14A

When the compressor current rises above Current_{max} the system displays P3 protection and the unit stops running. When the compressor current drops below Current_{max}, the compressor enters re-start control.

5.5 Voltage Protection Control

This control protects the OPTIMUS PRO Split from abnormally high or abnormally low voltages.



For single phase models, when the phase voltage of AC power supply is at or above 265V for more than 30 seconds, the system displays H7 protection and the unit stops running. When the phase voltage drops below 265V for more than 30 seconds, the refrigerant system restarts once the compressor re-start delay has elapsed. When the phase voltage is below 172V, the system displays H7 protection and the unit stops running. When the AC voltage rises to more than 180V, the refrigerant system restarts once the compressor re-start delay has elapsed.

For three phase models, when the phase voltage of AC power supply is at or above 457V for more than 30 seconds, the system displays H7 protection and the unit stops running. When the phase voltage drops below 440V for more than 30 seconds, the refrigerant system restarts once the compressor re-start delay has elapsed. When the phase voltage is below 298V, the system displays H7 protection and the unit stops running. When the AC voltage rises to more than 312V, the refrigerant system restarts once the compressor re-start delay has elapsed.

5.6 DC Fan Motor Protection Control

This control protects the DC fan motors from strong winds and abnormal power supply. DC fan motor protection occurs when any one of the following three sets of conditions are met:

- Outdoor ambient temperature is at or above 4°C and actual fan speed differs from target fan speed by 200rpm or more for more than 3 minutes.
- Outdoor ambient temperature is below 4°C and actual fan speed differs from target fan speed by 300rpm or more for more than 3 minutes.
- Actual fan speed is less than 150rpm for more than 90 seconds.

When DC fan motor protection control occurs the system displays the H6 error code and the unit stops running. After 3 minutes, the unit restarts automatically. When H6 protection occurs 10 times in 120 minutes, the HH error is displayed. When an HH error occurs, a manual system restart is required before the system can resume operation.

5.7 Water Side Heat Exchanger Anti-freeze Protection Control

This control protects the water side heat exchanger from ice formation.

In cooling mode, if inlet water temperature or leaving water temperature or auxiliary heat source leaving water temperature is below 4°C, heat pump stops and water pump keeps running for 30min. If water temperature is still below 4°C, heat pump turns to heating mode.

In heating/DHW standby mode, if ambient temperature is below 3°C and inlet water temperature or leaving water temperature or auxiliary heat source leaving water temperature is below 5°C, heat pump stops and water pump keeps running for 30min. If ambient temperature is still below 3°C and water temperature is still below 5°C, heat pump turns to heating mode.

In heating/DHW standby mode, if leaving water temperature is below 2°C, heat pump stops and water pump keeps running for 30min. If water temperature is still below 2°C heat pump turns to heating mode to protect from anti-freezing.

When water side heat exchanger anti-freeze protection occurs the system displays error code Pb and the unit stops running.

6 Special Control

6.1 Oil Return Operation

In order to prevent the compressor from running out of oil, the oil return operation is conducted to recover oil that has flowed out of the compressor and into the refrigerant piping.

The oil return operation starts when the following condition occurs:

- When the compressor cumulative operating time reaches 6 hours.

The oil return operation ceases when any one of the following three conditions occurs:

- Oil return operation duration reaches 5 minutes.
- Compressor stops.

Component control during oil return operation in cooling mode.

Component	Wiring diagram label	4-16kW	Control functions and states
Inverter compressor	COMP	●	Runs at oil return operation rotation speed
DC fan motor	FAN	●	Controlled according to cooling mode
Electronic expansion valve	EXV	●	304 (steps)
Four-way valve	4-WAY	●	Off

Component control during oil return operation in heating and DHW modes.

Component	Wiring diagram label	4-16kW	Control functions and states
Inverter compressor	COMP	●	Runs at oil return operation rotation speed
DC fan motor	FAN	●	Controlled according to heating mode
Electronic expansion valve	EXV	●	304 (steps)
Four-way valve	4-WAY	●	On

6.2 Defrosting Operation

In order to recover heating capacity, the defrosting operation is conducted when the outdoor unit air side heat exchanger is performing as a condenser. The defrosting operation is controlled according to outdoor ambient temperature, air side heat exchanger refrigerant outlet temperature and the compressor running time.

Component control during defrosting operation

Component	Wiring diagram label	4-16kW	Control functions and states
Inverter compressor	COMP	●	Runs at defrosting operation rotation speed
DC fan motor	FAN	●	Off
Electronic expansion valve	EXV	●	480 (steps)
Four-way valve	4-WAY	●	Off

6.3 Force Cooling Operation

The force cooling operation helps the refrigerant recovering before removal the water side heat exchanger.

Press the button on outdoor refrigerant system main PCB named "FORCE" for 5s to enter refrigerant recovery mode. If heat pump is standby before entering cooling mode, it will enter cooling mode directly. In other cases, heat pump will stop running current mode firstly and after 5min has passed, heat pump will change to cooling mode. After entering cooling mode, FC code appears on the PCB digital tube. When compressor starts, PCB digital tube displays compressor

frequency. When the system pressure is below 0.24MPa, the number 15 displays on the PCB and is reduced by 1 every 1s until 0. Then heat pump stops.

The force cool mode can be ended by pushing the button on the outdoor refrigerant system main PCB named "FORCE" for 5s or this mode will be ended automatic if the system has operated force cool mode for more than 30 minutes.

Component	Wiring diagram label	4-16kW	Control functions and states
Inverter compressor	COMP	•	Runs at force cooling operation rotation speed
DC fan motor	FAN	•	Runs at force cooling operation speed
Electronic expansion valve	EXV	•	304 (steps)
Four-way valve	4-WAY	•	Off

6.4 Fast DHW Operation

Fast DHW operation is used to quickly meet a requirement for domestic hot water when DHW priority has been set on the user interface.

Domestic hot water demand priority can be ended by changing the switch on controller from "on" to "off".

Component	Wiring diagram label	4/6kW	8/10/12/14/16kW	Control functions and states
Inverter compressor	COMP	•	•	Controlled according to load requirement
DC fan motor	FAN	•	•	Controlled according to outdoor heat exchanger pipe temperature
Electronic expansion valve	EXV	•	•	Position (steps) from 0 (fully closed) to 480 (fully open), controlled according to discharge superheat
Four-way valve	ST	•	•	On
Tank electric heater	TBH	•	•	On

6.5 Two zones control¹

Two zones control function is used to control temperature of each zone separately, thus different type radiator will operate at its optimal temperature and water pump cycle time will be reduced to save energy.

- Cooling mode

In two zones control for cooling mode, when the setting temperature of a certain zones is reached, the zone and water pump of this zone will turn off.

- Heating mode

In two zones control for heating mode, the on/off control of zone and water pump is same with cooling mode, but in addition, the mixing valve (3-way valve SV3) control function will be activated to adjust the water temperature of the low temperature zone by control the opening time and closing time of the valve. The mixing valve will only turn on when two zones control for heating is activated. On other conditions, the mixing valve will keep off. When the valve initially turns on, the opening time and closing time is same and then the time is controlled according to the difference between water pipe temperature and setting water temperature of the controlling zone.

- Hydraulic adapter PCB (Optional)

With the help of hydraulic adapter PCB, totally 8 thermostats can be used at the same time for maximum 8 rooms to control heat pump.

Note: 1.OPTIMUS PRO units just have the controlling function, while the mixing valve, water pump of each zone need to be field supplied and connect to OPTIMUS PRO unit.

OPTIMUS PRO Split

6.6 Smart grid control

Unit adjusts the operation according to different electrical signals to realize energy saving.

EVU signal	SG signal	Control
ON	ON	As long as the DHW mode is set to be valid, heat pump and IBH will operate in DHW mode at the same time automatically. When T5 rises to 60°C, DHW mode will exit and switch to cooling/heating mode normally.
ON	OFF	As long as the DHW mode is on, heat pump and IBH will operate in DHW mode at the same time automatically, when $T5 \geq \text{Min}(T5S+3,60)$, DHW mode will exit and switch to cooling/heating mode normally.
OFF	ON	Normal operation according to customers' requirement.
OFF	OFF	Prohibit DHW mode, IBH and disinfect operation. Heat pump runs cooling/heating mode for "SG RUNNING TIME" which is set on wired controller and then turns off.

Note:

1. EVU signal and SG signal are provided from the Smart Grid system
2. T5S means water tank setting temperature

6.7 Balance tank temperature control

Balance tank temperature sensor is used to control on/off of heat pump.

Once the heat pump stops, internal pump stops to save energy and then balance tank provides hot water for space heating. In addition, balance tank temperature control can meet both space heating and domestic hot water needs at the same time. Balance tank can store energy to provide hot water whilst heat pump runs heat mode/cooling, which can reduce the host selection and the initial investment.

6.8 Dry contract M1M2 control

M1M2 can be set in the wired controller for heat pump on/off control, TBH control, AHS control.

- For heat pump on/off control
When dry contract closes for 1s, heat pump stops. When dry contract opens for 5s, heat pump on/off according to wired controller or room thermostat setting.
- For TBH control
TBH is only controlled by M1M2. If dry contract closes, $T5 < 65^\circ\text{C}$ then TBH opens until water tank temperature reaches 70°C .
- For AHS control
In heating mode, AHS on/off is only controlled by M1M2. In DHW mode, M1M2 control does not affect AHS on/off.

6.9 USB data transfer

6.9.1 Parameters setting transfer between wired controllers

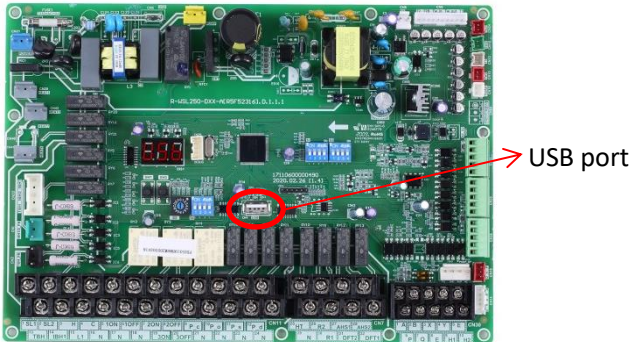
Installer can quickly copy the wired controller parameter settings from unit A to unit B via USB disk, which save the time of on-site installation. Steps are as follows:

Step 1:

Plug U disk into the port of hydro PCB of A unit.

“USB” appears on digital display

Wired controller interface automatically changes



USB FUNCTION
READ SET PARAMETER
WRITE SET PARAMETER
OK ↕

Step 2:

Select “READ SET PARAMETER” and press “OK” button then rate of progress will appear. When the process is finished, “SUCCESS” appears below and an EXCEL file which can not be seen in the wired controller interface but users can find it on computer will be generated inside the USB disk.

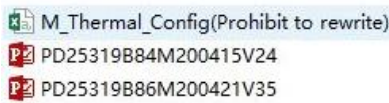
Select “READ SET PARAMETER”

Finished

EXCEL generated

USB FUNCTION
READ SET PARAMETER 63%
WRITE SET PARAMETER
OK ↕

USB FUNCTION
READ SET PARAMETER
WRITE SET PARAMETER
OK SUCCESS ↕



After that, if parameter correction is needed, please connect the USB with computer and open the EXCEL file to change parameters and then save it. Please do not change the file name or format. Parameters are not allowed for non-professionals to change and NØRDIS recommends to use the wired controller to change the parameters.

Step 3:

Plug USB disk into the port of hydro PCB of B unit and select “WRITE SET PARAMETER” then rate of progress will appear. When the process is finished, “SUCCESS” appears below.

Select “WRITE SET PARAMETER”

Finished

USB FUNCTION
READ SET PARAMETER
WRITE SET PARAMETER 25%
OK ↕

USB FUNCTION
READ SET PARAMETER
WRITE SET PARAMETER
OK SUCCESS ↕

OPTIMUS PRO Split

6.9.2 Convenient program upgrade for unit

There is no need to carry any heavy equipment but only USB disk can realize program upgrade. Steps are as follows:

Step 1:

Copy new program in U disk root directory where other files in bin format are not allowed in

Step 2:

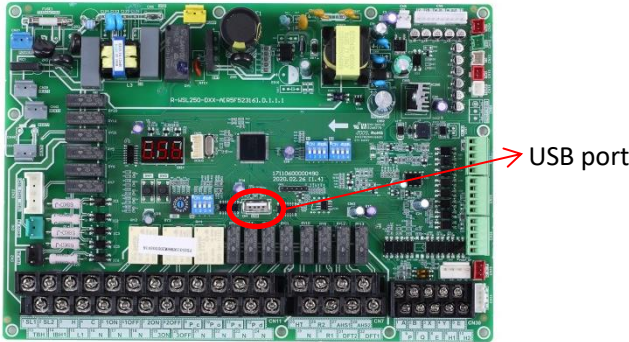
Power on and make sure communication is normal.

Step 3:

Plug U disk into the port of hydro PCB.

“USB” appears on digital display

Wired controller interface automatically changes



USB FUNCTION
READ SET PARAMETER
WRITE SET PARAMETER
PD25319B84M200415V24.bin
PD25319B86M200421V35.bin
OK ↕

Step 4:

Please distinguish between programs for main control PCB and hydro PCB. Select one of them and press “OK” button then rate of progress appears. When the process is finished, “SUCCESS” appears below. For upgrading outdoor unit, the process normally lasts for several minutes while only few seconds is needed for indoor unit.

Select program

Finished

USB FUNCTION
READ SET PARAMETER
WRITE SET PARAMETER
PD25319B84M200415V24.bin 51%
PD25319B86M200421V35.bin
OK ↕

USB FUNCTION
READ SET PARAMETER
WRITE SET PARAMETER
PD25319B84M200415V24.bin
PD25319B86M200421V35.bin
OK SUCCESS ↕

Step 5:

Pull out U disk and power on again to finish upgrading program. Check the program version to make sure upgrade is successful.

Check IDU software version

Check ODU software version

OPERATION PARAMETER	#00
Tbt1 BUFFERTANK_UP TEMP.	XX °C
Tbt2 BUFFERTANK_LOW TEMP.	XX °C
Tsolar	XX °C
IDU SOFTWARE	XX-XX-XXXXXXX
↔ ADDRESS	5/9 ↕

OPERATION PARAMETER	#00
T3 OUTDOOR EXCHANGE TEMP.	XX °C
T4 OUTDOOR AIR TEMP	XX °C
TF MODULE TEMP.	XX °C
P1 COMP PRESSURE	XX Kpa
ODU SOFTWARE	XX-XX-XXXXXXX
HMI SOFTWARE	XX-XX-XXXXXXX
↔ ADDRESS	9/9 ↕

Part 4

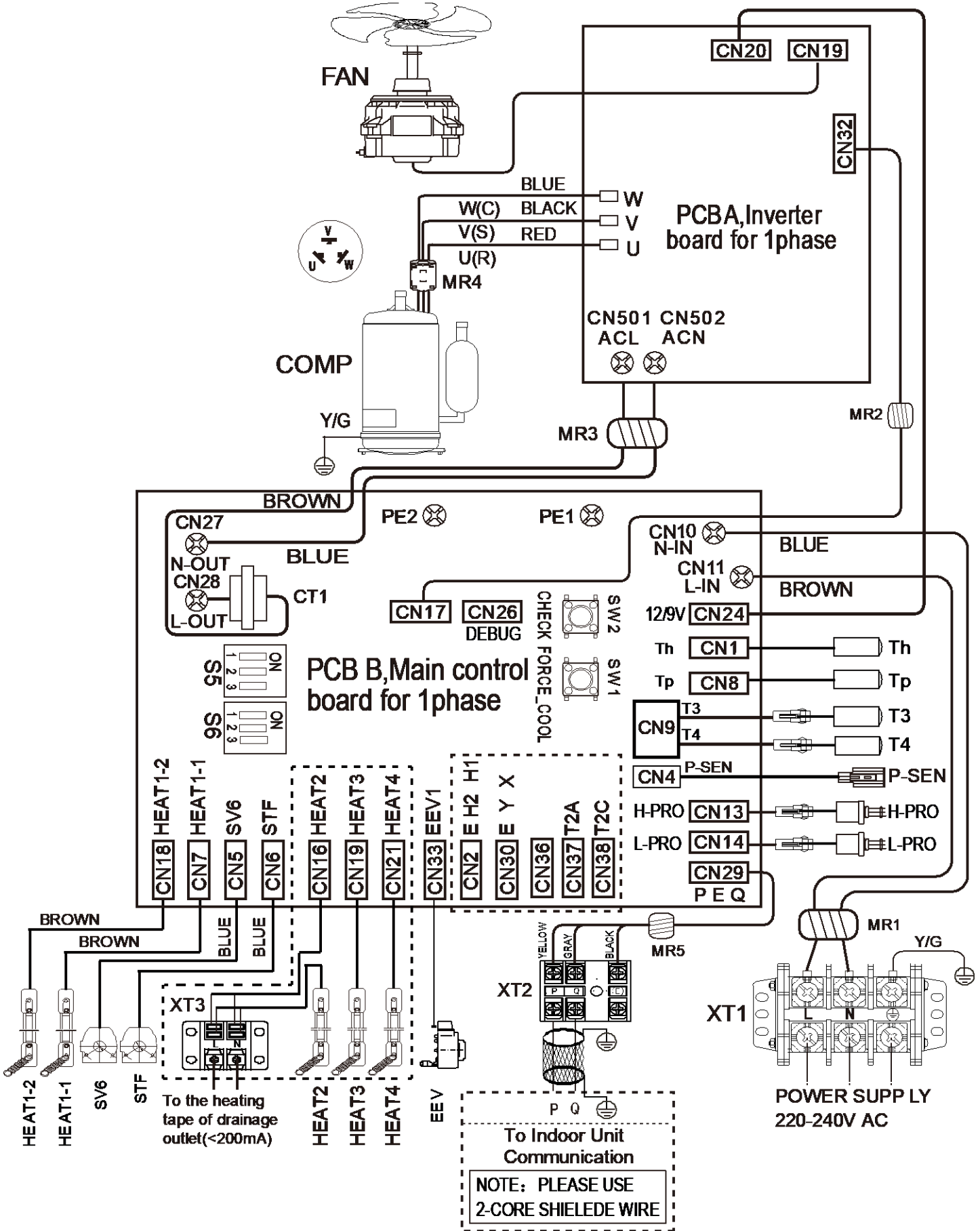
Diagnosis and Troubleshooting

1 Electric wiring diagram.....	30
2 DIP Switch Settings.....	35
3 Electric Control Box Layout.....	36
4 PCBs.....	39
5 Error Code Table.....	53
6 Troubleshooting.....	55
7 USB function guidelines.....	112
8 Appendix to Part 4.....	114

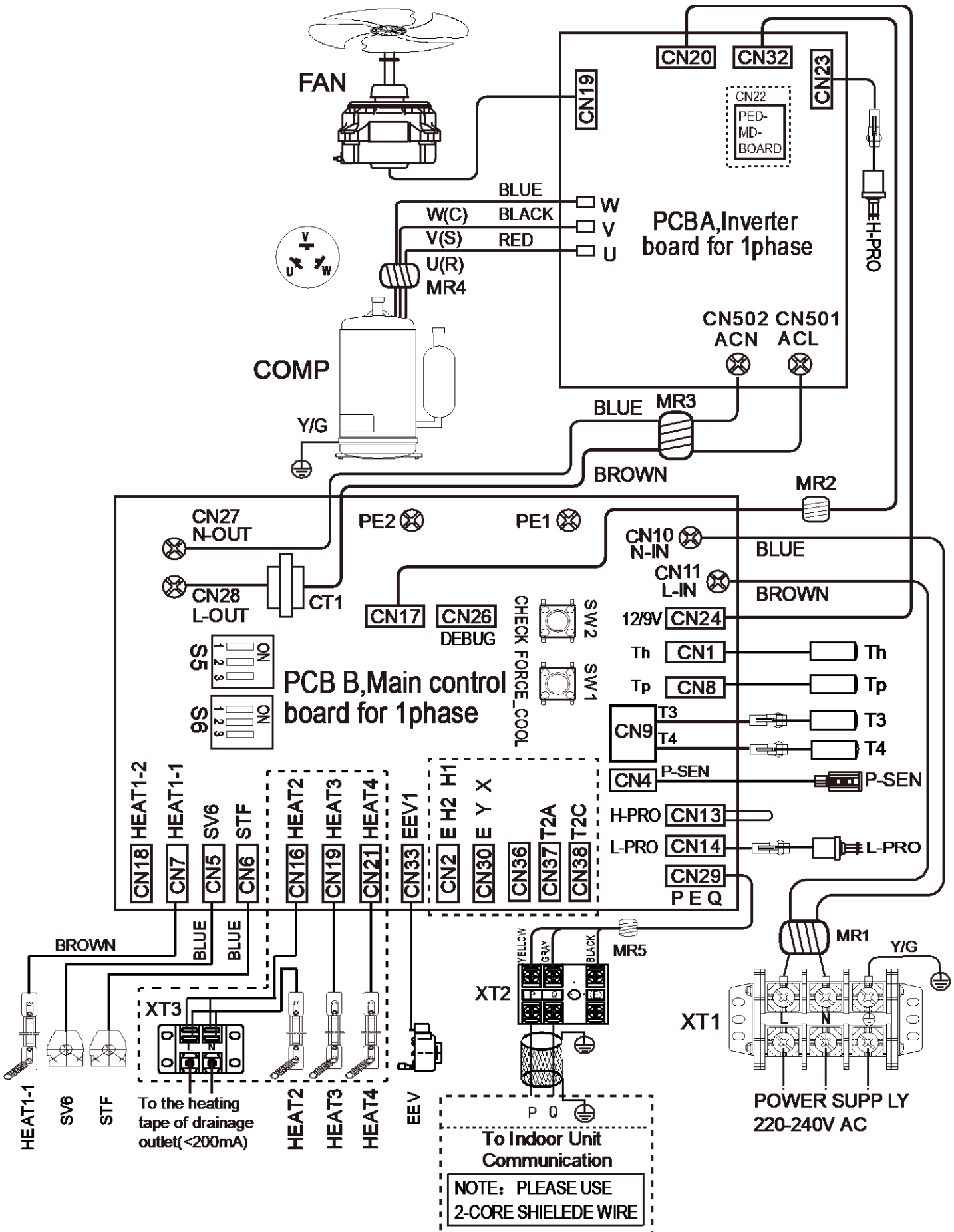
OPTIMUS PRO Split

1 Electric wiring diagram

Outdoor unit 4~10kW

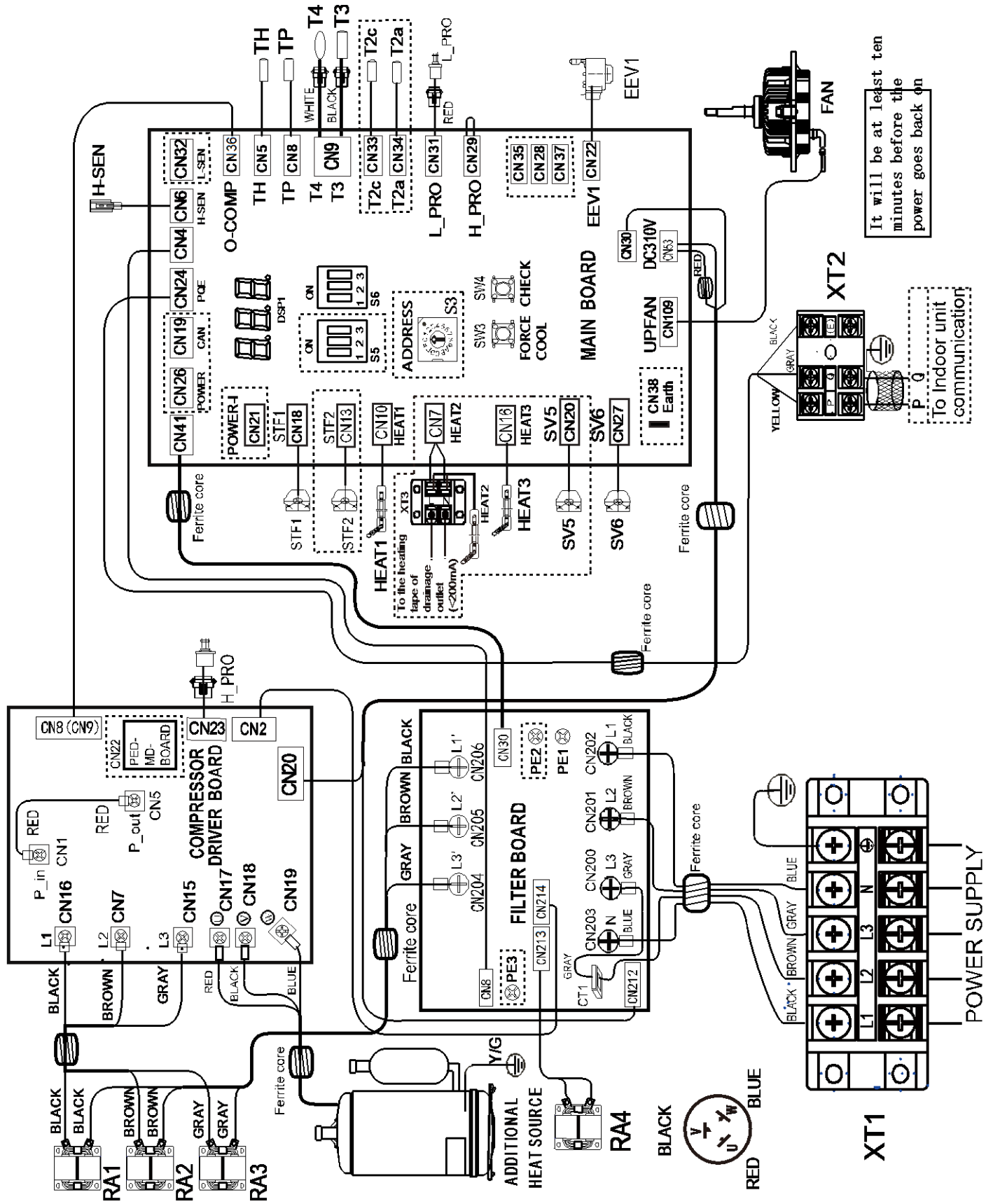


Outdoor unit 12~16kW Single Phase

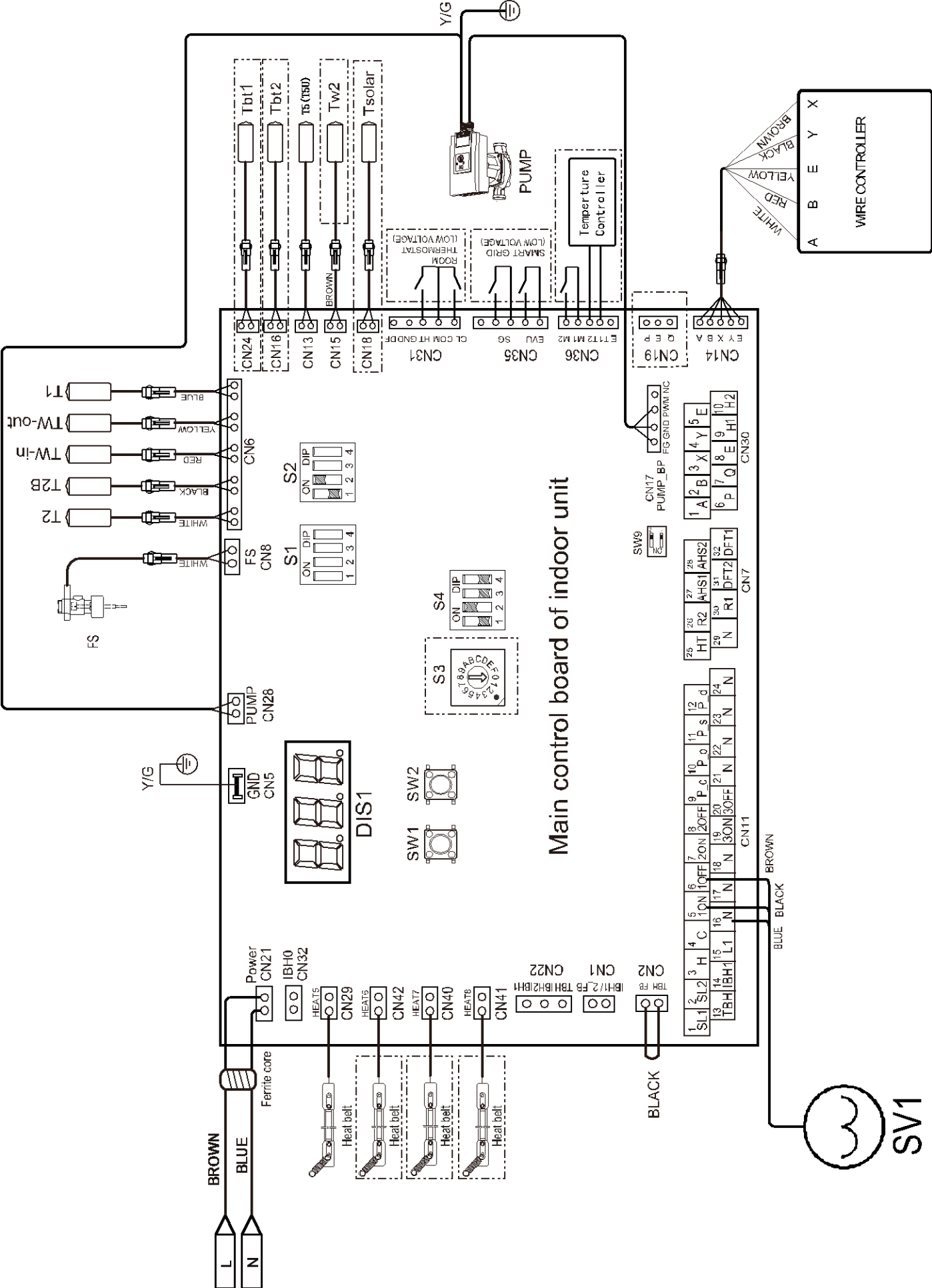


OPTIMUS PRO Split

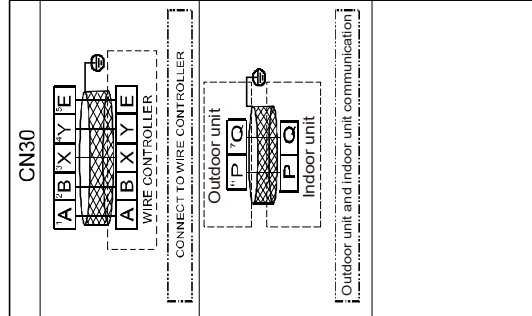
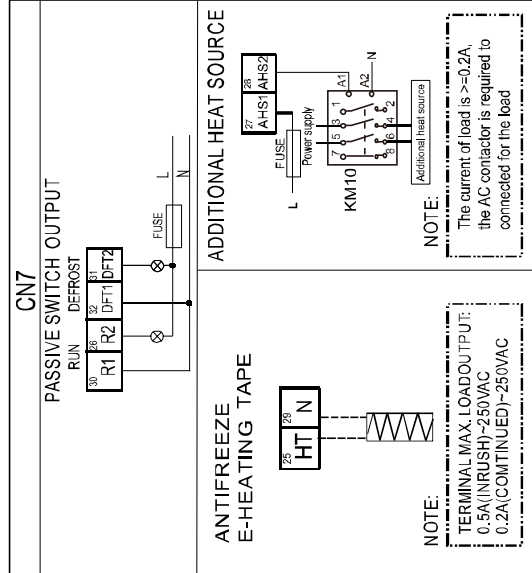
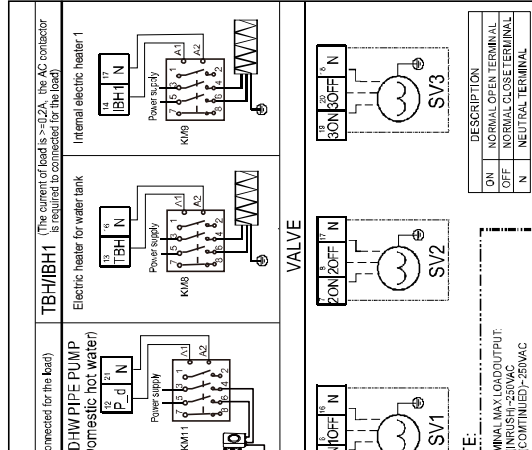
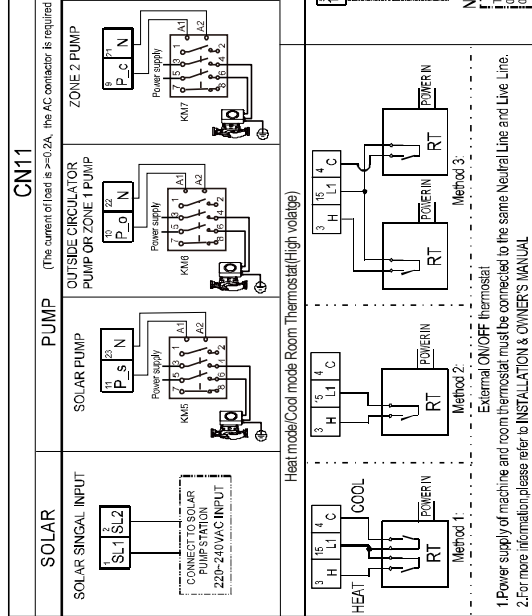
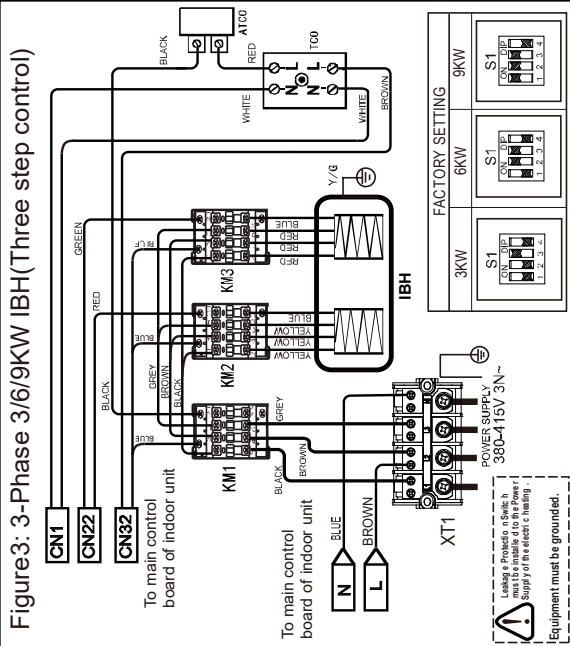
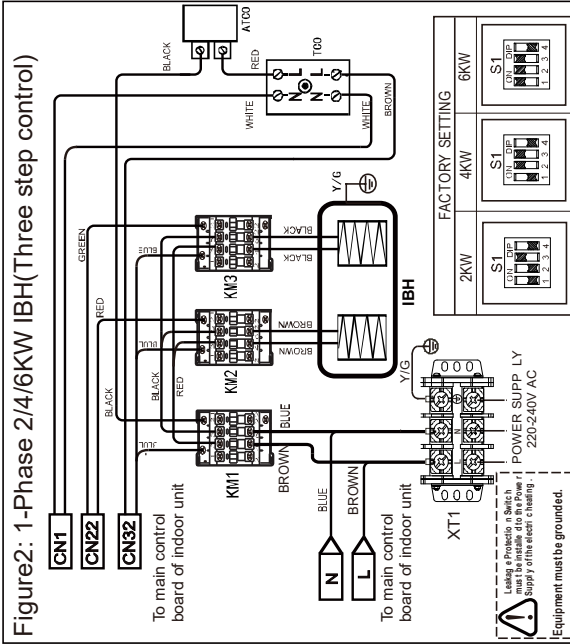
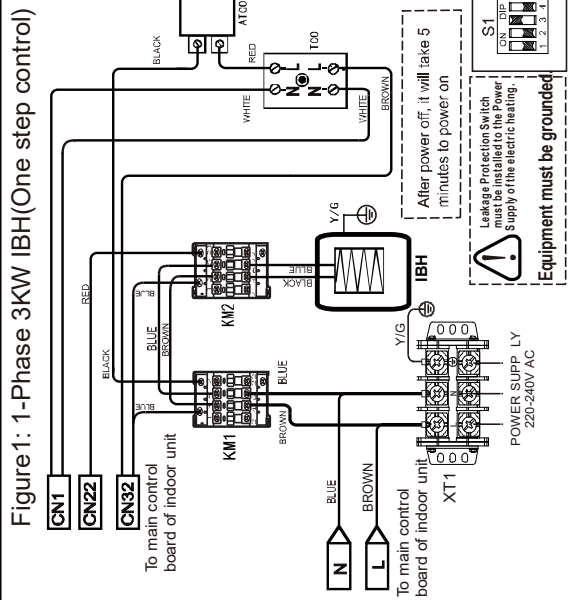
Outdoor unit 12~16kW Three Phase



Hydro module with tank






OPTIMUS PRO Split



2 DIP Switch Settings

DIP switch is located on the hydraulic module main control board, please refer below for more details setting.

Switch		ON=1	OFF=0	
S1 	1/2	00=IBH(One-step control) 01=IBH(Two-step control) 11=IBH(Three-step control)		Set according to unit configuration by factory
	3/4	00=Without IBH and AHS 10=With IBH 01=With AHS for heating mode 11=With AHS for heating mode and DHW		Set according to unit configuration by factory or adjust onsite according to applicaiton
S2 	1	Start Pump O after 24 hours will be invalid	Start Pump O after 24 hours will be valid	OFF
	2	without TBH	with TBH	ON
	3/4	Pump configuration		ON/ON
S4 	1	Reserved		OFF
	2	IBH for DHW=valid	IBH for DHW=invalid	ON
	3/4	Reserved		OFF

OPTIMUS PRO Split

3 Electric Control Box Layout

3.1 Outdoor Unit Electric Control Box Layout

Figure 4-1.1: HOP4(6)WODU electric control box

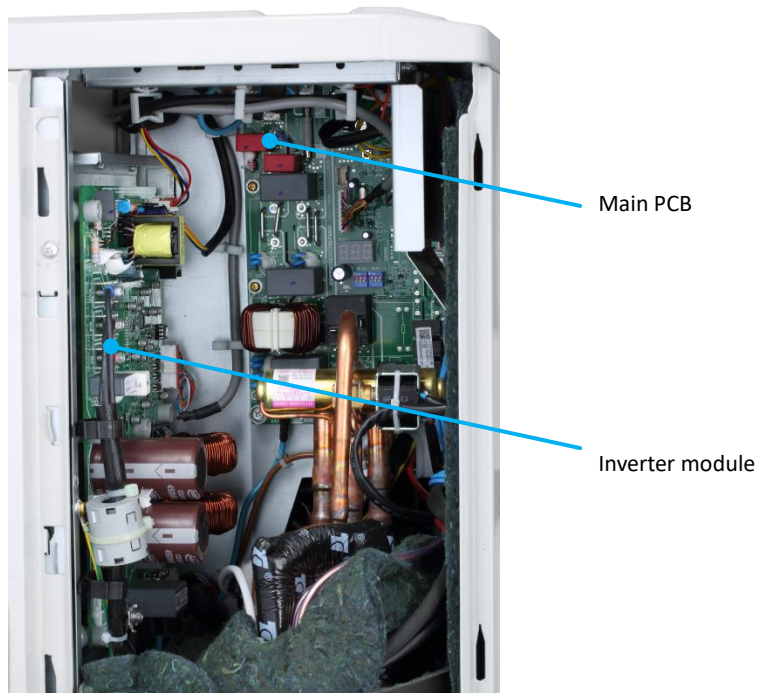


Figure 4-1.2: HOP8(10)WODU electric control box

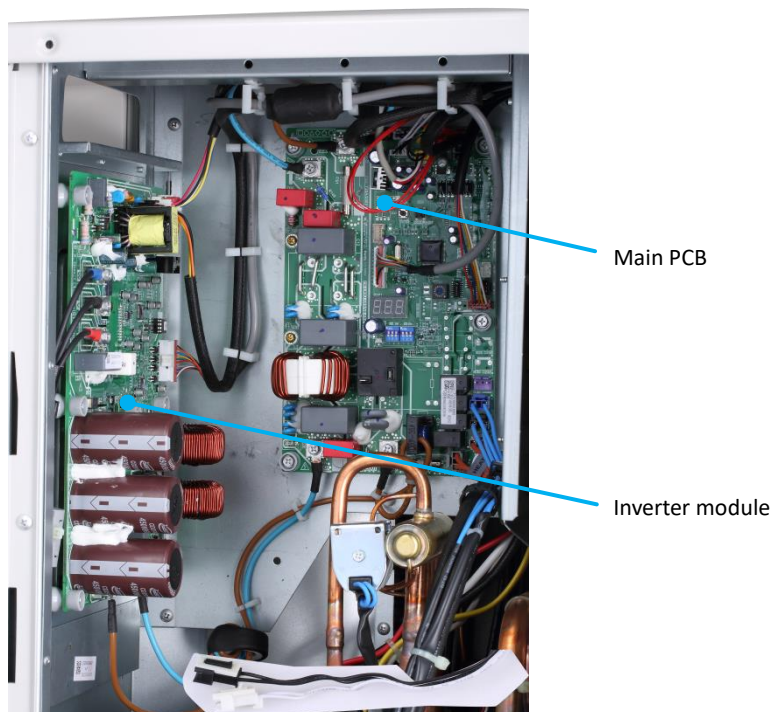


Figure 4-1.3: HOP12(14,16)WODU electric control box

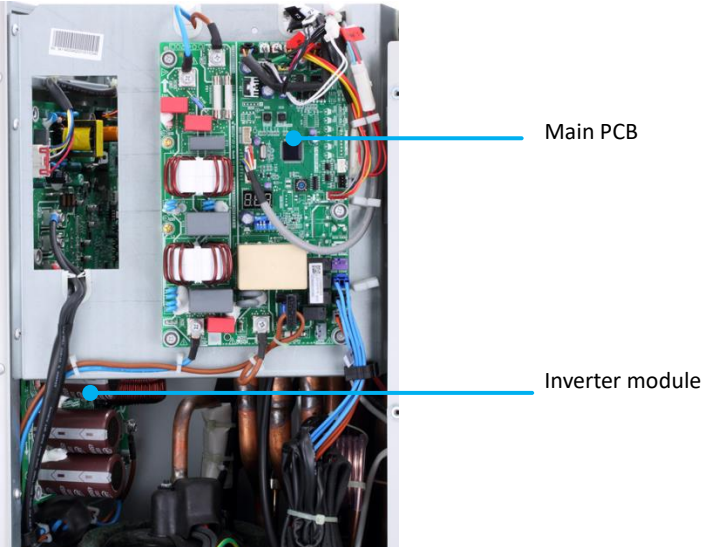
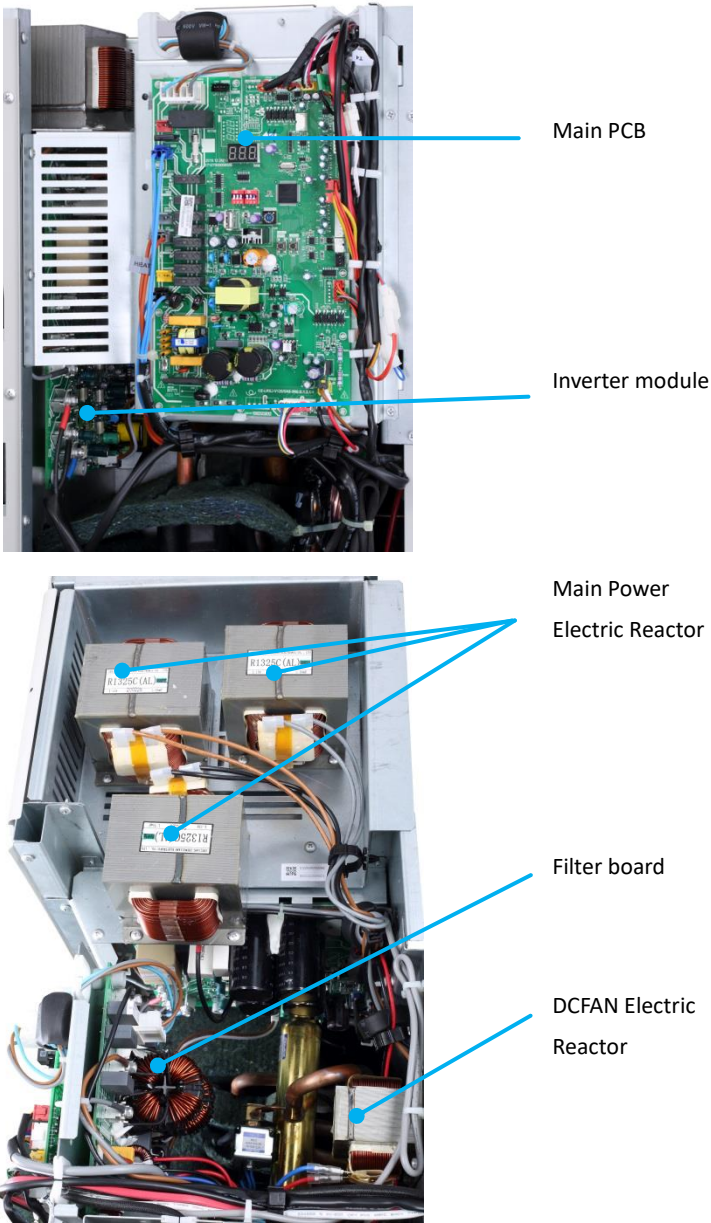


Figure 4-1.4: HOP12(14,16)WODU3 electric control box



OPTIMUS PRO Split

3.2 Hydronic Box Electric Control Box Layout

Figure 4-1.5:HOP100/190IDU, HOP100/240IDU electric control box

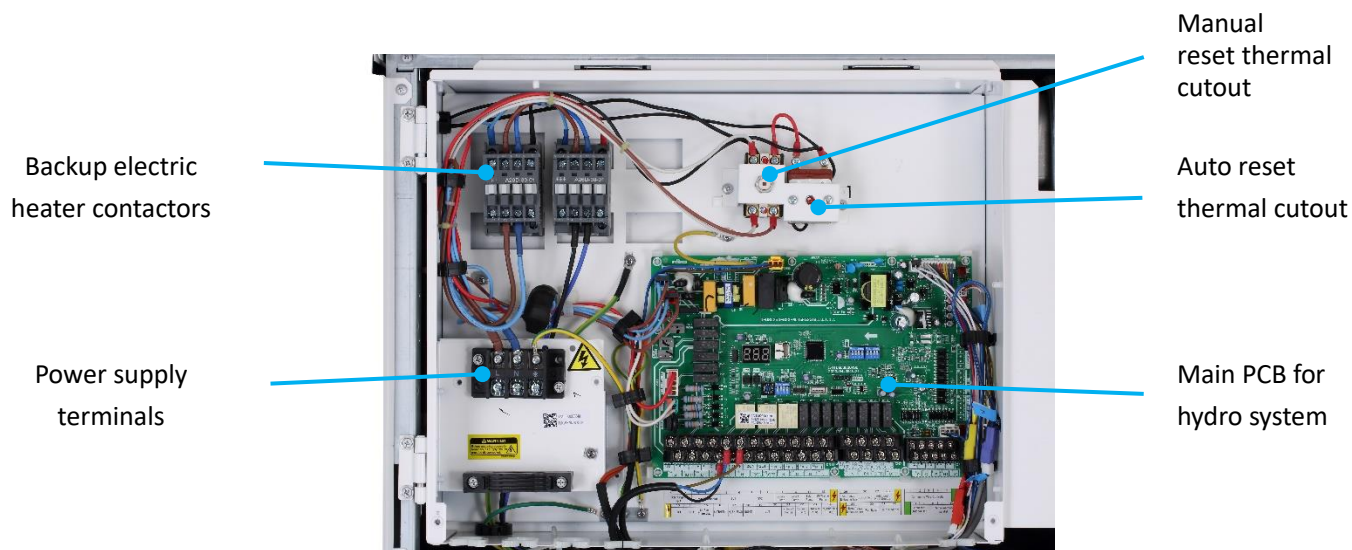
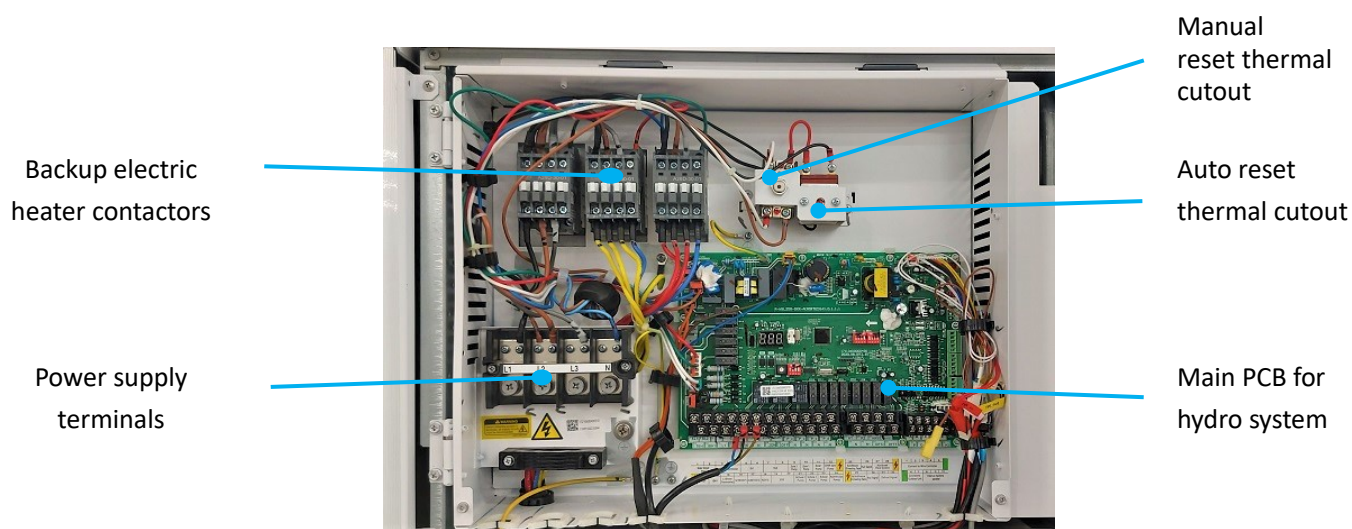


Figure 4-1.6:HOP100/190IDU3, HOP100/240IDU3, HOP160/240IDU3 electric control box



4 PCBs

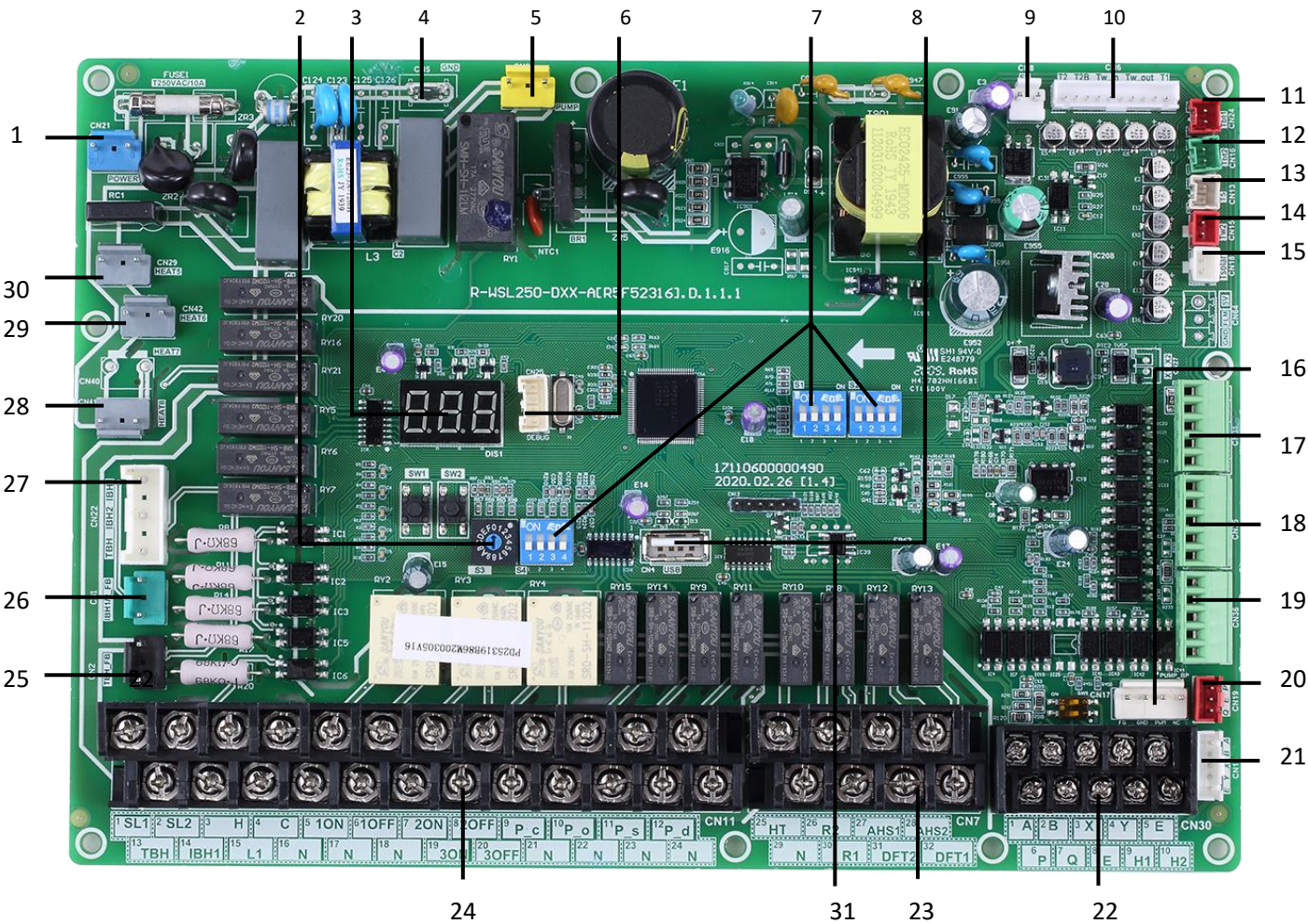
4.1 Outdoor Unit PCBs

There are one type of main PCB for the 4kW to 16kW models. In addition to the main PCB, all models have an inverter module.

The locations of each PCB in the outdoor unit electric control box are shown in Figures 4-1.1 to Figure 4-1.4 in Part 4, 1.1 "Outdoor Unit Electric Control Box Layout". The locations of each PCB in the hydronic box electric control box are shown in Figures 4-1.5 in Part 4, 1.2 "Hydronic Box Electric Control Box Layout".

4.2 Main PCB for Hydronic System

Figure 4-2.1: Hydronic box main PCB



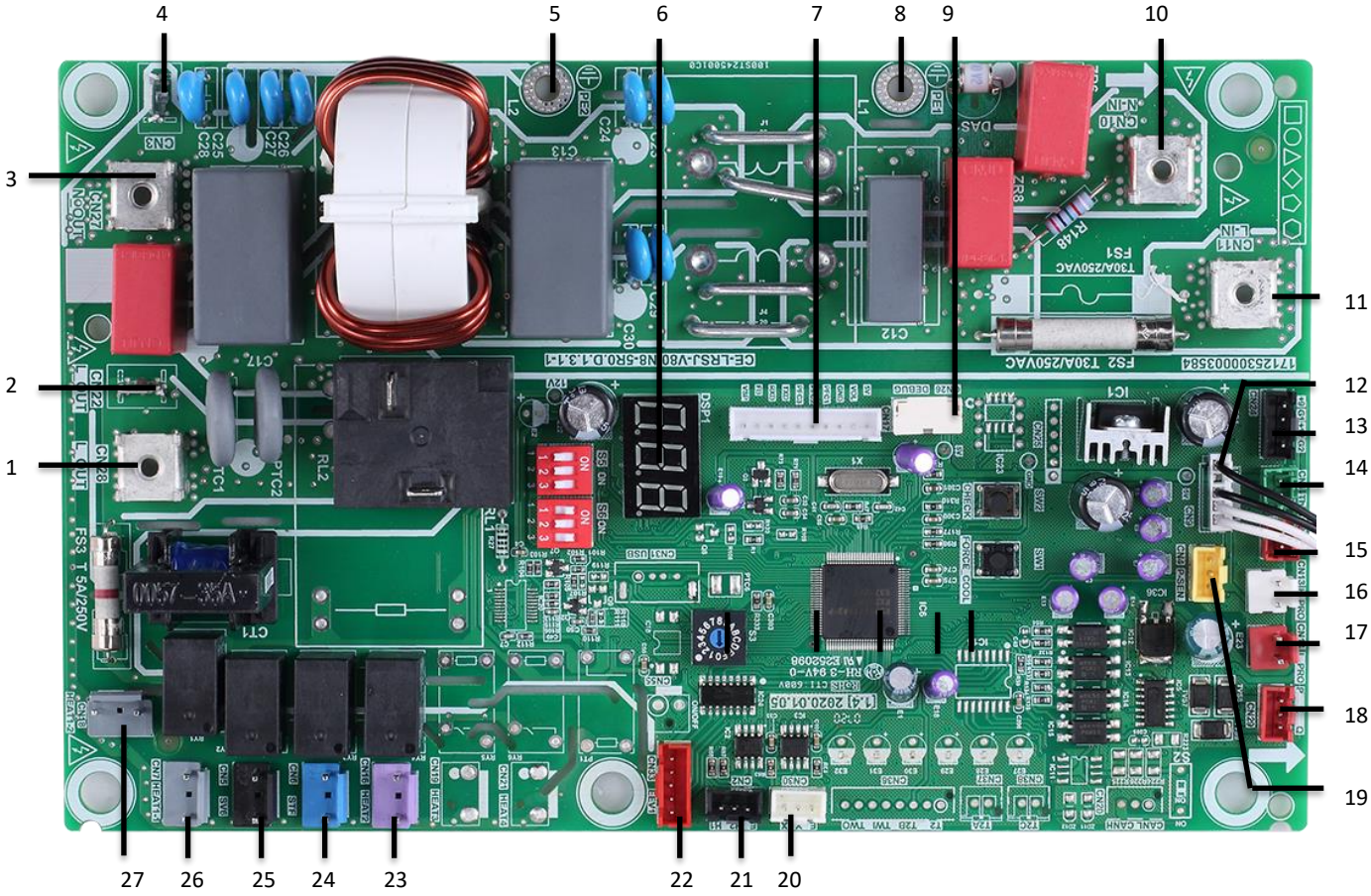
OPTIMUS PRO Split

Table 4-2.1: Hydronic box main PCB

Label in Figure 4-2.1	Code	Content
1	CN21	Port for power supply
2	S3	Rotary dip switch
3	DIS1	Digital display
4	CN5	Port for ground
5	CN28	Port for variable speed pump power input
6	CN25	Port for IC programming
7	S1,S2,S4	Dip switch
8	CN4	Port for USB programming
9	CN8	Port for Flow switch
10	CN6	Port for temp. sensors (T2,T2B,TW_out,TW_in, T1,)
11	CN24	Port for temp. sensor(Tbt1, The balanced water tank of up temp. sensor)
12	CN16	Port for temp. sensor(Tbt2, The balanced water tank of up temp. sensor)
13	CN13	Port for temp. sensor(T5, domestic hot water tank temp. sensor)
14	CN15	Port for temp. sensor(Tw2, The outlet water for zone 2 temp. sensor)
15	CN18	Port for temp. sensor(Tsolar, Solar panel temp. sensor)
16	CN17	Port for variable speed pump communication
17	CN31	Control port for room thermostat (heating mode)(HT)/Control port for room thermostat (cooling mode)(CL)/Power port for room thermostat(COM)
18	CN35	Port for smart grid (grid signal, photovoltaic signal)
19	CN36	Port for remote switch, temperature board
20	CN19	Communicate port between indoor unit and outdoor unit
21	CN14	Port for communication with the wired controller
22	CN30	Communicate port between indoor unit and outdoor unit, port for communication with the wired controller, internal machine parallel
23	CN7	Port for antifreeze E-heating tape(external), additional heat source, compressor run/defrost run
24	CN11	Control port for tank booster heater, internal backup heater 1, input port for solar energy, Port for room thermostat, SV1(3-way valve), SV2(3-way valve), SV3(3-way valve), zone 2 pump, outside circulation pump, solar energy pump, DHW pipe pump,
25	CN2	Feedback port for external temp. switch(shorted in default)
26	CN1	Feedback port for temperature switch(shorted in default)
27	CN22	Control port for backup heater1/booster heater/Reserved
28	CN41	Port for anti-freeze electric heating tape
29	CN42	Port for anti-freeze electric heating tape
30	CN29	Port for anti-freeze electric heating tape
31	IC39	EEPROM

4.3 Main PCBs for Refrigerant System, Inverter Module

Figure 4-2.2: HOP4(6,8,10)WODU outdoor unit main PCB for refrigerant system

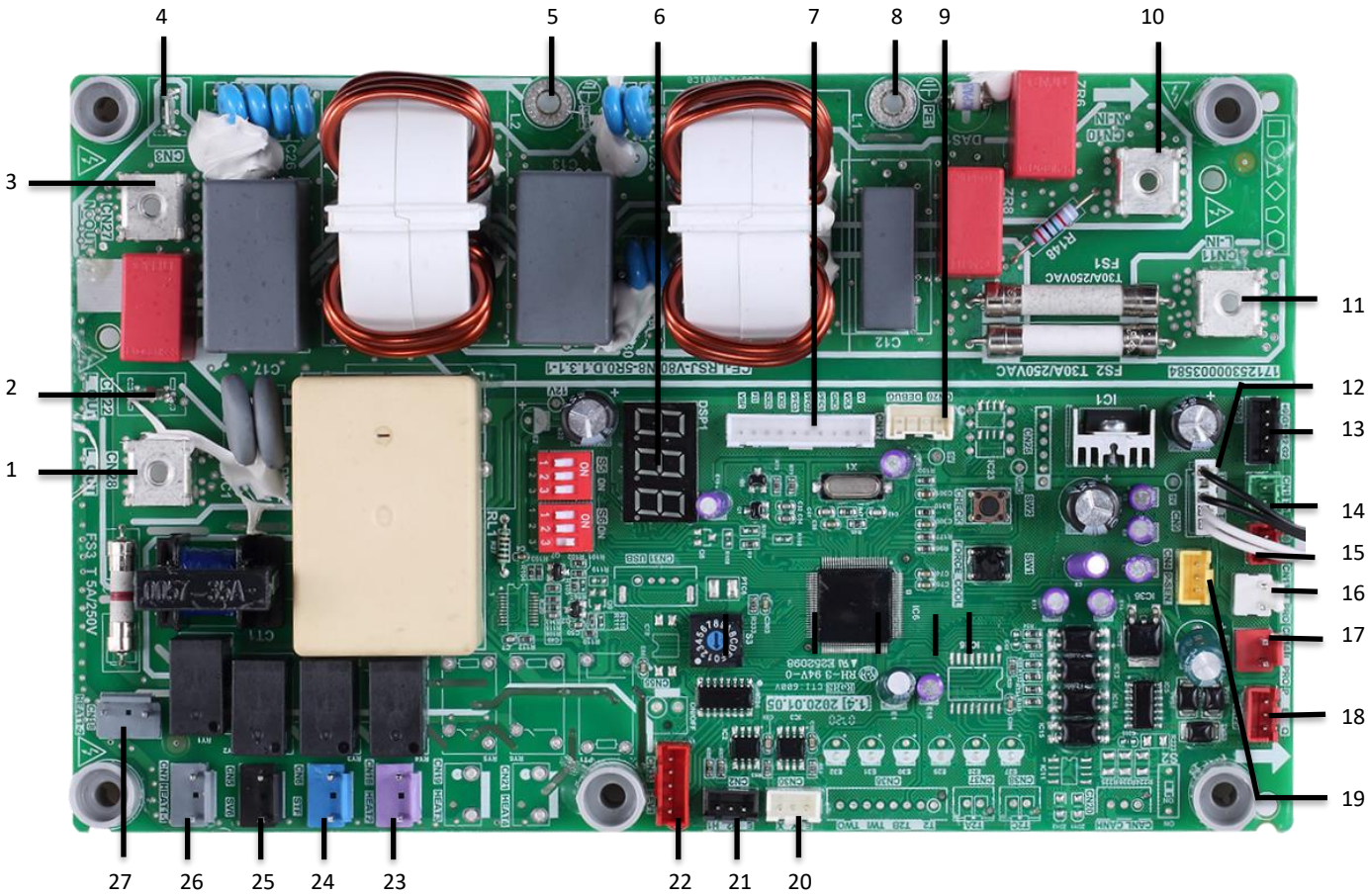


OPTIMUS PRO Split

Table 4-2.2: HOP4(6,8,10)WODU outdoor unit main PCB for refrigerant system

Label in Figure 4-2.2	Code	Content
1	CN28	Output port L to main PCB for refrigerant system
2	CN22	Reserved
3	CN27	Output port N to main PCB for refrigerant system
4	CN3	Reserved
5	PE2	Port for ground wire
6	DSP1	Digital display
7	CN17	Port for communication with main PCB for refrigerant system
8	PE1	Port for ground wire
9	CN26	Reserved
10	CN10	Input port for neutral wire
11	CN11	Input port for live wire
12	CN9	Port for outdoor ambient temp. sensor and condenser temp. sensor
13	CN24	Input port for +12V/9V
14	CN1	Port for suction temp. sensor
15	CN8	Port for discharge temp. sensor
16	CN13	Port for high pressure switch
17	CN14	Port for low pressure switch
18	CN29	Port for communication with hydro-box control board
19	CN4	Port for pressure sensor
20	CN30	Port for communication(reserved)
21	CN2	Port for communication(reserved)
22	CN33	Port for electrical expansion valve
23	CN16	Port for chassis electrical heating tape(Optional)
24	CN6	Port for 4-way valve
25	CN5	Port for SV6 valve
26	CN7	Port for compressor electric heating tape 1
27	CN18	Port for compressor electric heating tape 2

Figure 4-2.3 HOP12(14,16)WODU outdoor unit main PCB for refrigerant system

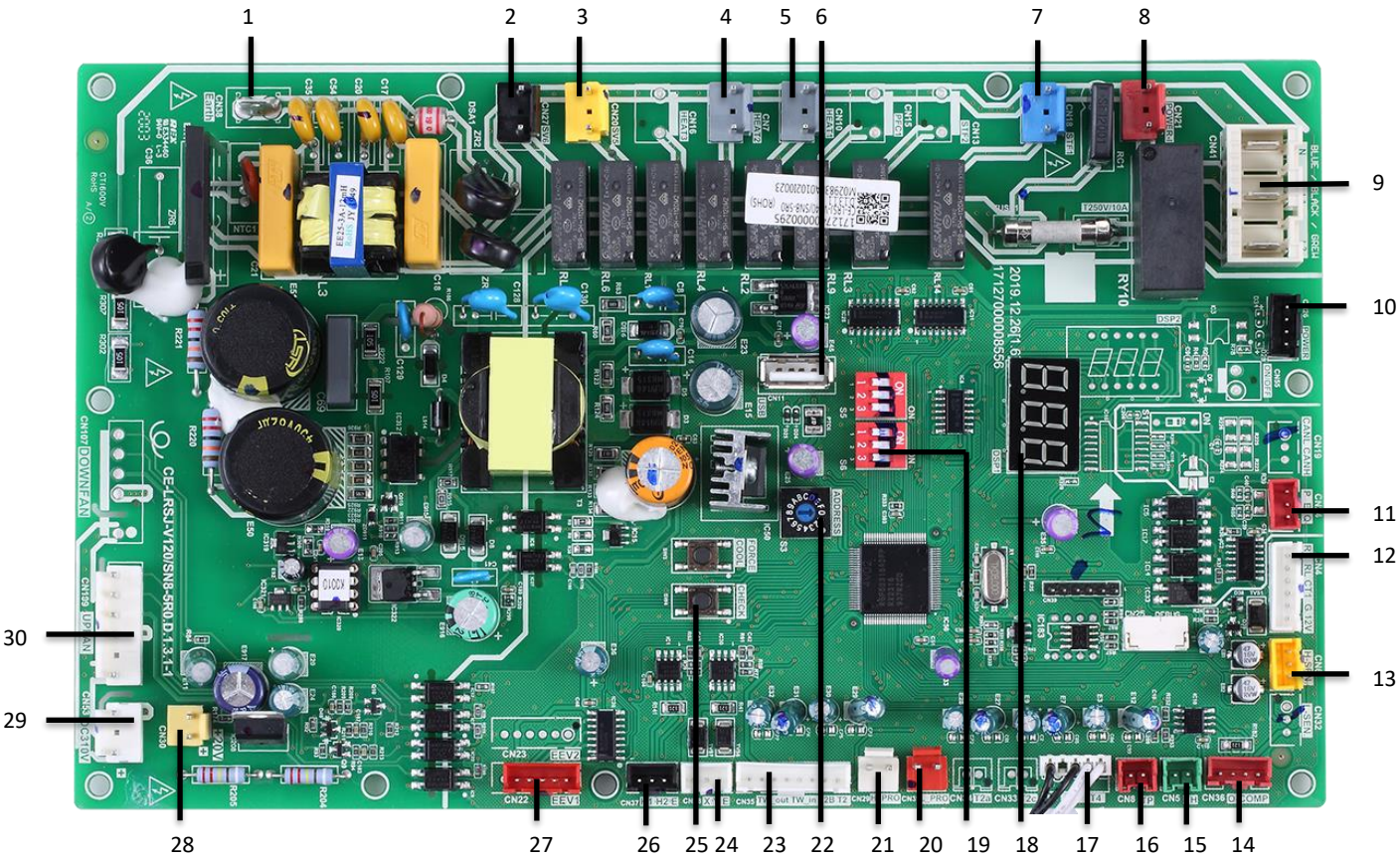


OPTIMUS PRO Split

Table 4-2.3: HOP12(14,16)WODU outdoor unit main PCB for refrigerant system

Label in Figure 4-2.3	Code	Content
1	CN28	Output port L to main PCB for refrigerant system
2	CN22	Reserved
3	CN27	Output port N to main PCB for refrigerant system
4	CN3	Reserved
5	PE2	Port for ground wire
6	DSP1	Digital display
7	CN17	Port for communication with main PCB for refrigerant system
8	PE1	Port for ground wire
9	CN26	Reserved
10	CN10	Input port for neutral wire
11	CN11	Input port for live wire
12	CN9	Port for outdoor ambient temp. sensor and condenser temp. sensor
13	CN24	Input port for +12V/9V
14	CN1	Port for suction temp. sensor
15	CN8	Port for discharge temp. sensor
16	CN13	Port for high pressure switch
17	CN14	Port for low pressure switch
18	CN29	Port for communication with hydro-box control board
19	CN4	Port for pressure sensor
20	CN30	Port for communication(reserved)
21	CN2	Port for communication(reserved)
22	CN33	Port for electrical expansion valve
23	CN16	Port for chassis electrical heating tape(Optional)
24	CN6	Port for 4-way valve
25	CN5	Port for SV6 valve
26	CN7	Port for compressor electric heating tape 1
27	CN18	Port for compressor electric heating tape 2

Figure 4-2.4 HOP12(14,16)WODU3 outdoor unit main PCB for refrigerant system



OPTIMUS PRO Split

Table 4-2.4: HOP12(14,16)WODU3 outdoor unit main PCB for refrigerant system

Label in Figure 4-2.4	Code	Content
1	CN38	Port for GND
2	CN27	Port for 2-way valve 6
3	CN20	Port for 2-way valve 5
4	CN7	Port for electric heating tape2
5	CN10	Port for electric heating tape1
6	CN11	Reserved
7	CN18	Port for 4-way valve
8	CN21	Reserved
9	CN41	Power supply port from main PCB for invert module board
10	CN26	Port for communication with Power Meter
11	CN24	Port for communication with hydro-box control board
12	CN4	Port for communication with main PCB for invert module board
13	CN6	Port for pressure sensor
14	CN36	Port for communication with main PCB for refrigerant system
15	CN5	Port for temp. sensor Th
16	CN8	Port for temp. sensor Tp
17	CN9	Port for outdoor ambient temp. sensor and condenser temp. sensor
18	DSP1	Digital display(DSP1)
19	S5,S6	DIP switch(S5,S6)
20	CN31	Port for low pressure switch(CN31)
21	CN29	Port for high pressure switch and quick check(CN29)
22	S3	Rotary dip switch(S3)
23	CN35	Port for temp. sensors(TW_out, TW_in, T1, T2,T2B)
24	CN28	Port for communication XYE
25	S3, S4	Key for fore cool & check
26	CN37	Port for communication H1H2E
27	CN22	Port for electrical expansion valve
28	CN30	Port for fan 15VDC power supply
29	CN53	Port for fan 310VDC power supply
30	CN109	Port for fan

Table 4-2.5: HOP4(6,8,10)WODU outdoor unit inverter module

Label in Figure 4-2.5	Code	Content
1	U	Compressor connection port U
2	V	Compressor connection port V
3	W	Compressor connection port W
4	CN20	Output port for +12V/9V
5	CN19	Port for fan
6	CN32	Port for communication with main PCB for filter board
7	CN502	Input port N for rectifier bridge
8	CN501	Input port L for rectifier bridge
9	IC320	EEPROM

Figure 4-2.6: HOP12(14,16)WODU outdoor unit inverter module

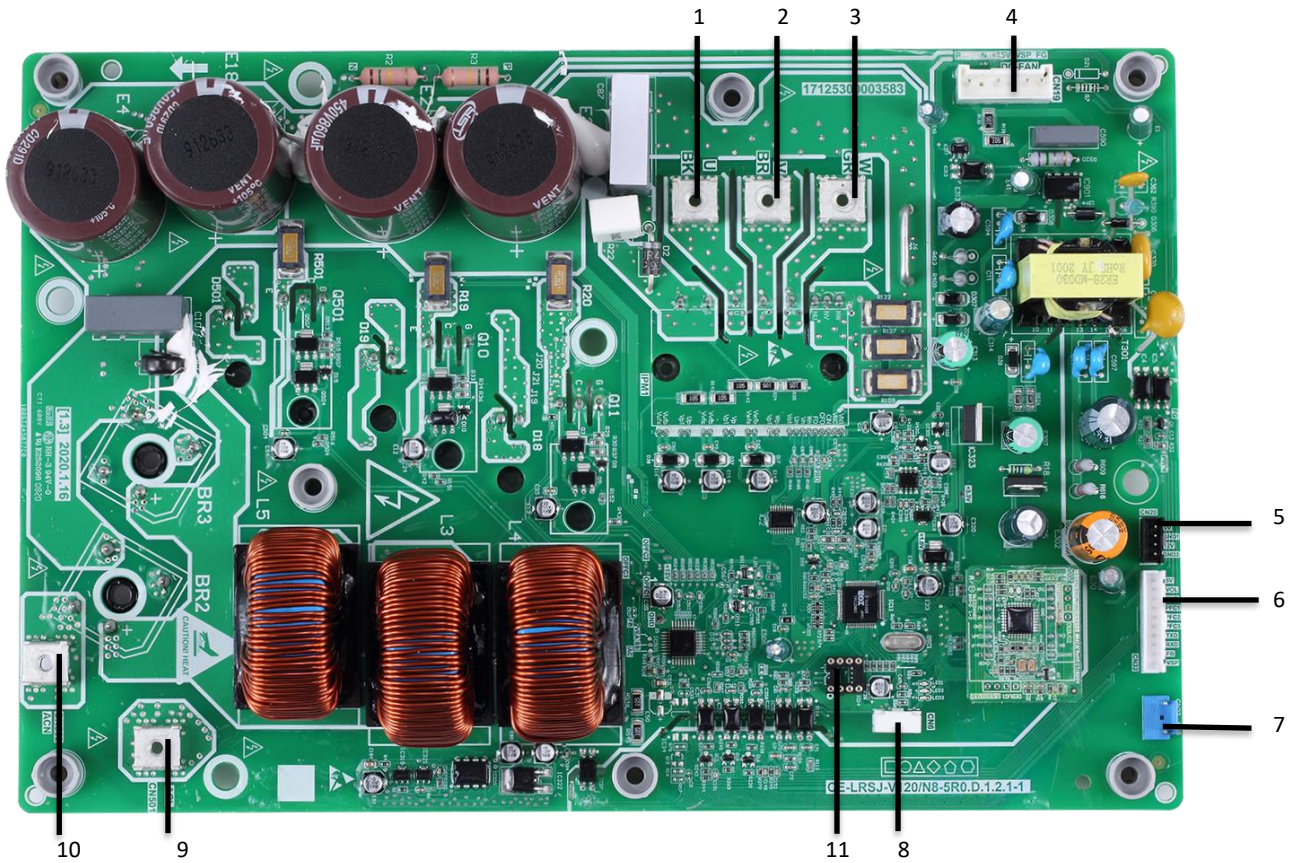


Table 4-2.6: HOP12(14,16)WODU outdoor unit inverter module

Label in Figure 4-2.6	Code	Content
1	U	Compressor connection port U
2	V	Compressor connection port V
3	W	Compressor connection port W
4	CN19	Port for fan
5	CN20	Output port for +12V/9V
6	CN32	Port for communication with main PCB for filter board
7	CN23	Port for high pressure switch
8	CN6	Reserved
9	CN501	Input port L for rectifier bridge
10	CN502	Input port N for rectifier bridge
11	IC14	EEPROM

OPTIMUS PRO Split

Figure 4-2.7: HOP12(14,16)WODU3 outdoor unit inverter module

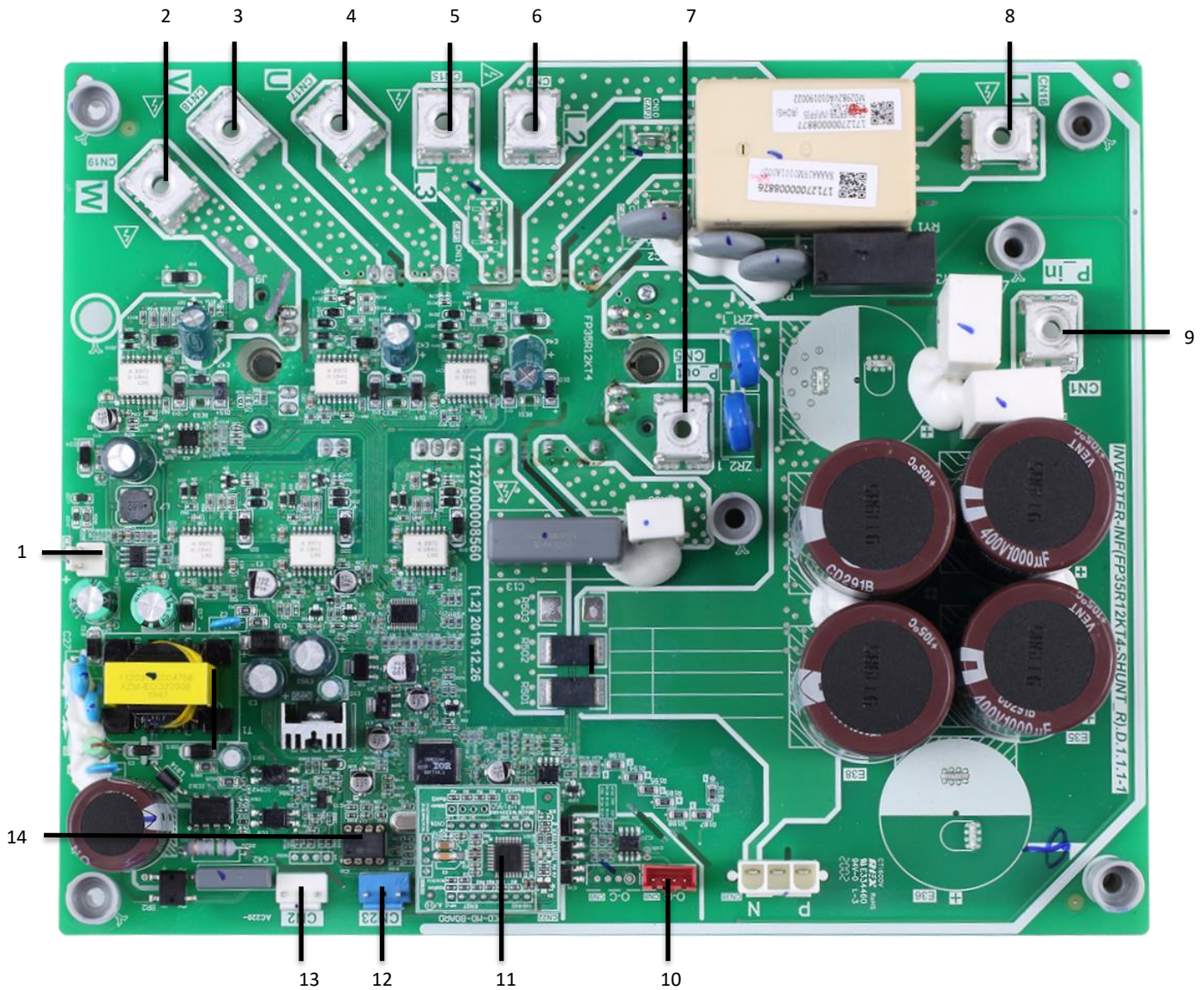


Table 4-2.7: HOP12(14,16)WODU3 outdoor unit inverter module

Label in Figure 4-2.7	Code	Content
1	CN20	Output port for +15V
2	CN19	Compressor connection port W
3	CN18	Compressor connection port V
4	CN17	Compressor connection port U
5	CN15	Power Input port L3
6	CN7	Power Input port L2
7	CN5	Input port P_out for IPM module
8	CN16	Power Input port L1
9	CN1	Input port P_in for IPM module
10	CN8	Port for communication with main PCB for filter board
11	CN22	PED board
12	CN23	Power for high pressure switch
13	CN2	Port for communication with PCB
14	IC25	EEPROM

Figure 4-2.8: HOP12(14,16)WODU3 outdoor unit filter board

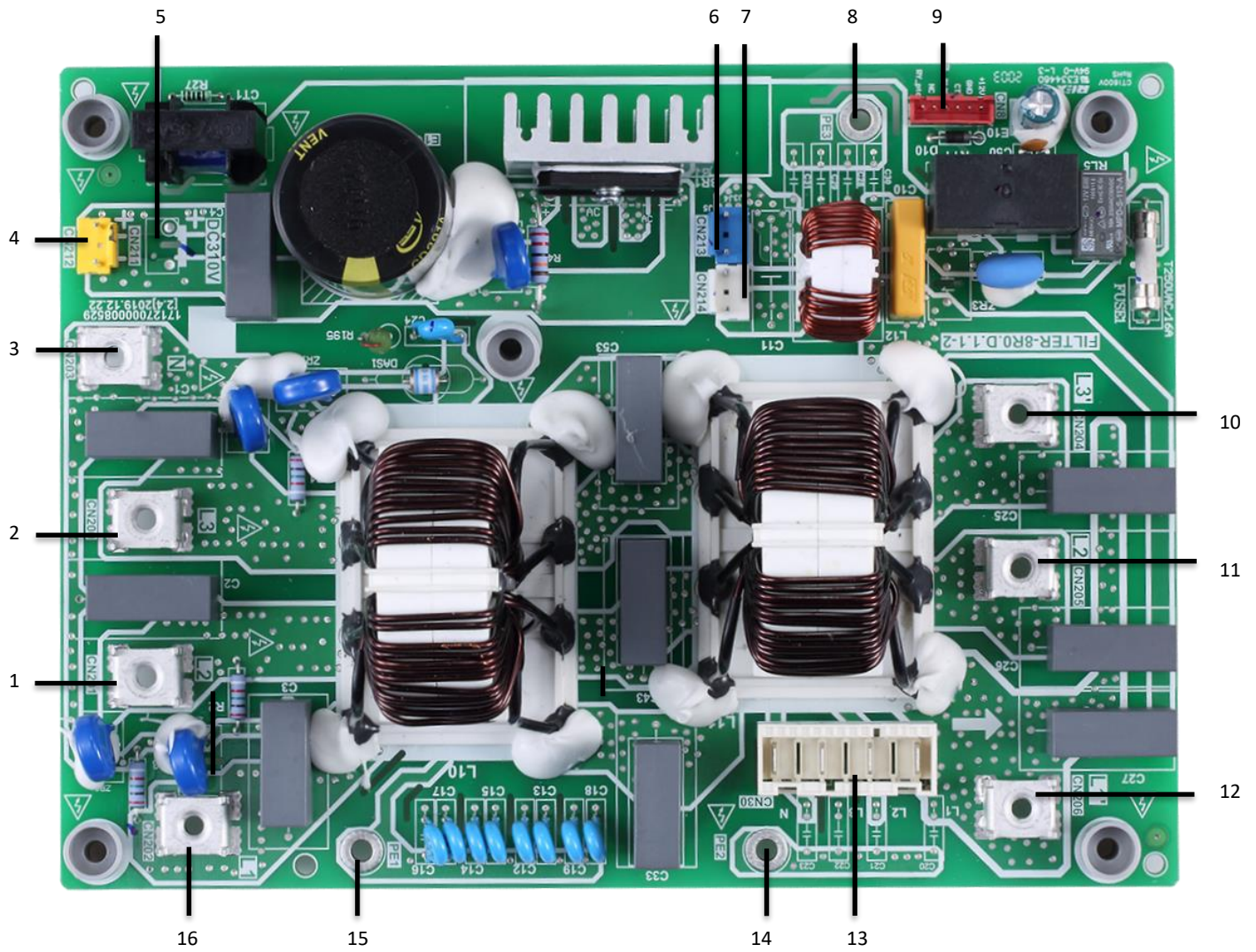



Table 4-2.8: HOP12(14,16)WODU3 outdoor unit filter board

Label in Figure 4-2.8	Code	Content
1	CN201	Power supply L2
2	CN200	Power supply L3
3	CN203	Power supply N
4	CN212	Power supply port of 310VDC
5	CN211	Reserved
6	CN213	Port for FAN Reactor
7	CN214	Power supply port for Inverter module
8	PE3	Ground wire
9	CN8	Port for communication with main PCB for filter board
10	L3'	Power filtering L3
11	L2'	Power filtering L2
12	L1'	Power filtering L1
13	CN30	Power supply port for main control board
14	PE2	Port for ground wire
15	PE1	Port for ground wire
16	L1	Power supply L1

OPTIMUS PRO Split

4.4 Digital Display Output

Table 4-2.9: Digital display output in different operating states

OPTIMUS PRO Split system state	Parameters displayed on outdoor unit main PCB DSP1	Parameters displayed on hydronic box main PCB DSP1	
On standby	0	0	
Normal operation	Running speed of the compressor in rotations per second	Leaving water temperature (°C)	
Error or protection	Error or protection code	Error or protection code	

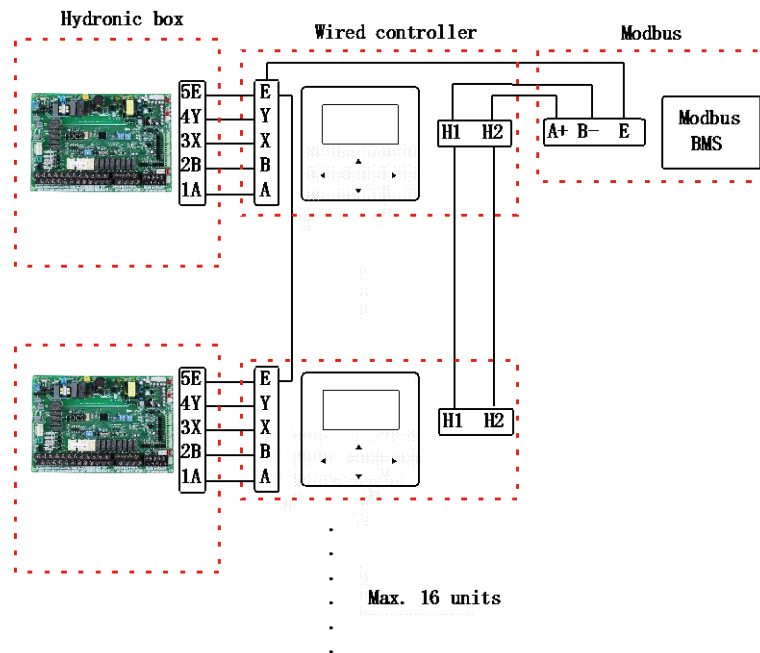
4.5 DIP switch setting and Modbus function

The rotating coded switch S3(0-F) on the main control board of hydraulic module is used for setting the modbus address. By default the units have this coded switch positioned=0, but this corresponds to the modbus address 16, while the others positions corresponds the number, e.g. pos=2 is address 2, pos=5 is address 5.

Figure 4-2.10: Rotating switch

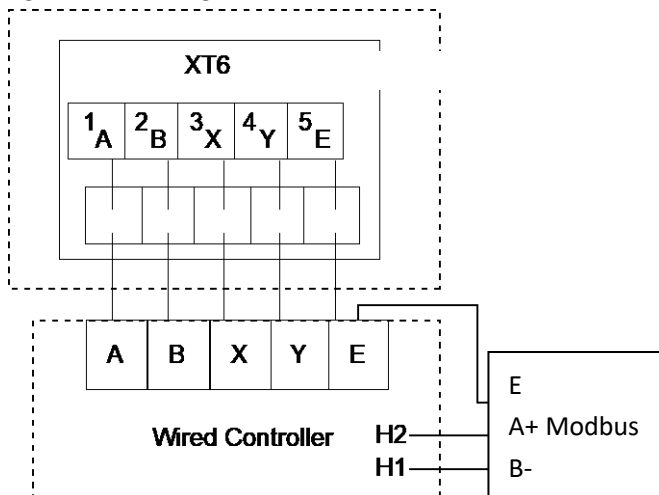


Figure 4-2.11: Connection



Note: Wired controller is integrated in the hydronic box.

Figure 4-2.12: Wiring



Input Voltage(A/B)	13.5VAC
Wiring size	0.75mm ²

5 Error Code Table

Table 4-3.1: Error code table

Error code	Serial Number ¹	Content ²	Remarks
C7	65	High temperature protection of transducer module	
E0	1	Water flow failure(E8 appears for 3 times)	
E1	2	Phase sequence error	Only applies to 3-phase models
E2	3	Communication error between the main control board of hydraulic module and user interface	
E3	4	Final outlet water temperature sensor error	Sensor T1
E4	5	Domestic hot water tank temperature sensor error	Sensor T5
E5	6	Air side heat exchanger refrigerant outlet temperature sensor error	Sensor T3
E6	7	Outdoor ambient temperature sensor error	Sensor T4
E7	8	Balance tank upper temperature sensor error	Sensor Tbt1
E8	9	Water flow failure	
E9	10	Suction pipe temperature sensor error	Sensor Th
EA	11	Discharge pipe temperature sensor error	Sensor Tp
Eb	12	Solar panel temperature sensor error	Sensor Tsolar
Ec	13	Balance tank nether temperature sensor error	Sensor Tbt2
Ed	14	Water side heat exchanger water inlet temperature sensor error	Sensor Tw_in
EE	15	Hydronic box EEPROM error	
F1	116	DC generatrix voltage is too low	
H0	39	Communication error between outdoor unit main control chip and hydronic box main control chip	
H1	40	Communication error between outdoor unit main control chip and inverter driver chip	
H2	41	Water side heat exchanger refrigerant outlet (liquid pipe) temperature sensor error	Sensor T2
H3	42	Water side heat exchanger refrigerant inlet (gas pipe) temperature sensor error	Sensor T2B
H4	43	P6 appear 3 times in one hour	
H5	44	Room temperature sensor error	Sensor Ta
H6,	45	DC fan error	
H7	46	Abnormal main circuit voltage	
H8	47	Pressure sensor error	
H9	48	Circuit 2 water outlet temperature sensor error	Sensor Tw2
HA	49	Water side heat exchanger water outlet temperature sensor error	Sensor Tw_out
Hb	50	PP protection appears three times in a row and Twout<7°C	
HF	54	Invert module EEPROM error	
HH	55	DC fan error(H6 appears 10 times in 120min)	
HP	57	Low pressure protection for cooling mode	
P0	20	Low pressure switch protection	
P1	21	High pressure switch protection	
P3	23	Compressor current protection	
P4	24	Discharge temperature protection	

Table continued on next page ...

OPTIMUS PRO Split

Table 4-3.1: Error code table (continued)

P5	25	High temperature difference between water side heat exchanger water inlet and water outlet temperatures protection	
P6	26	Inverter module protection	
L0	-	Inverter module protection	
L1	-	DC bus low voltage protection	
L2	-	DC bus high voltage protection	
L4	-	MCE error	
L5	-	Zero speed protection	
L7	-	Phase sequence error	
L8	-	Compressor frequency variation greater than 15Hz within one second protection	
L9	-	Actual compressor frequency differs from target frequency by more than 15Hz protection	
Pb	31	Water side heat exchanger anti-freeze protection	
Pd	33	High temperature protection of refrigerant outlet temperature of condenser in cooling mode	
PP	38	Water side heat exchanger inlet temperature is higher than outlet temperature in heating mode or DHW mode	
bH	112	PED board error	

Notes:

1. When the error code appears, the error code corresponding to the serial number can be obtained through the H1H2 port by using the host computer to query the wired controller register.
2. Sensor names in this service manual referring to refrigerant flow is named according refrigerant flow during cooling operation refer to Part 2, 3 "Refrigerant Flow Diagrams".

6 Troubleshooting

6.1 Warning

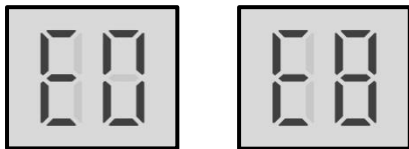
Warning

- All electrical work must be carried out by competent and suitably qualified, certified and accredited professionals and in accordance with all applicable legislation (all national, local and other laws, standards, codes, rules, regulations and other legislation that apply in a given situation).
- Power-off the outdoor units before connecting or disconnecting any connections or wiring, otherwise electric shock (which can cause physical injury or death) may occur or damage to components may occur.

OPTIMUS PRO Split

6.2 E0, E8 Troubleshooting

6.2.1 Digital display output



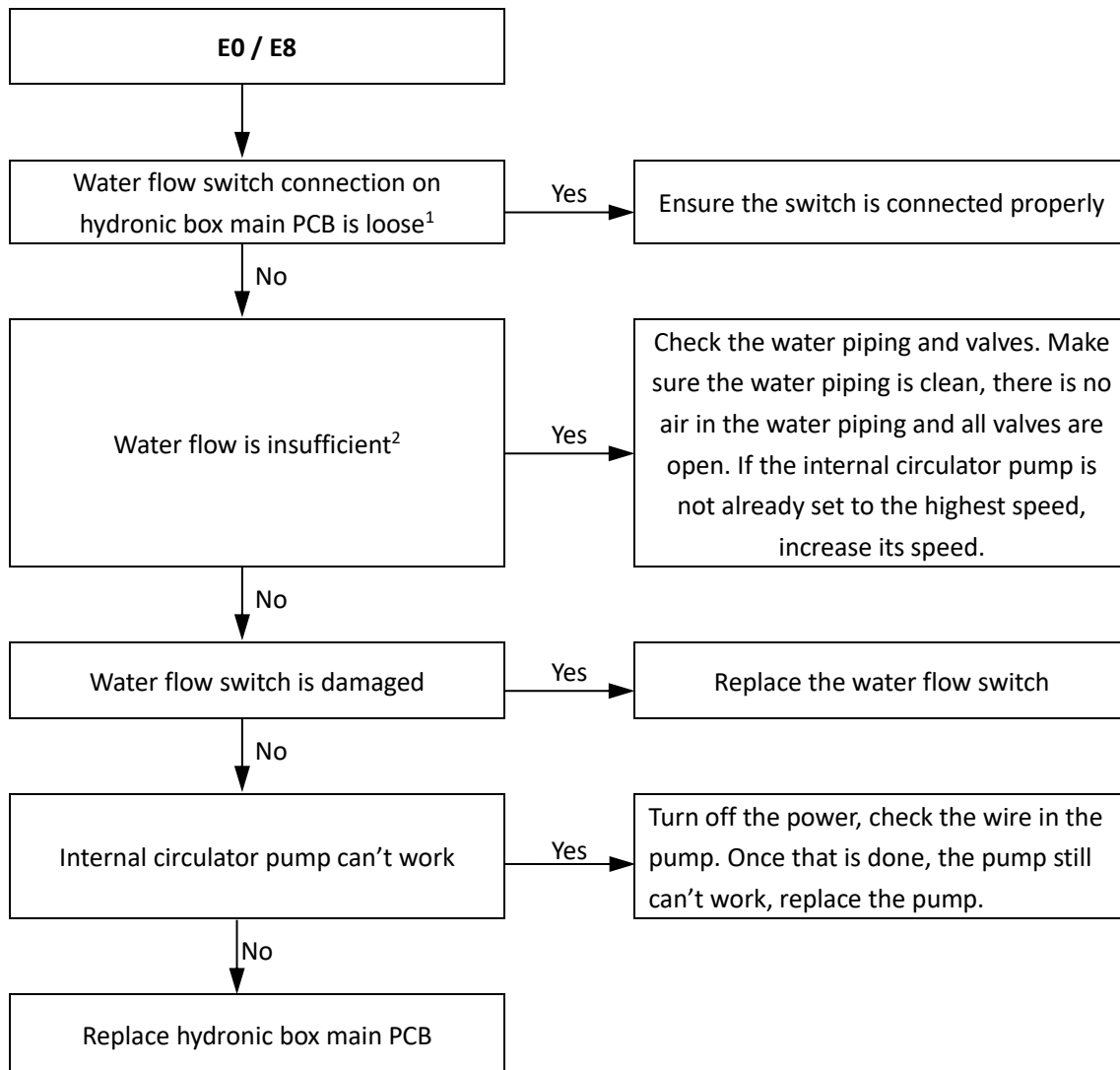
6.2.2 Description

- Water flow failure.
- E0 indicates E8 has displayed 3 times. When an E0 error occurs, a manual system restart is required before the system can resume operation.
- OPTIMUS PRO Split stops running.
- Error code is displayed on hydronic box main PCB and user interface.

6.2.3 Possible causes

- The wire circuit is short connected or open.
- Water flow rate is too low.
- Water flow switch damaged.

6.2.4 Procedure



Notes:

1. Water flow switch connection is port CN8 on the main PCB for hydronic box (labeled 9 in Figure 4-2.1 in Part4, 2.2 "Main PCB for Hydronic System").
2. Check water pressure on the manometer. If the water pressure is not > 1 bar, water flow is insufficient. Refer to Figure 2-1.9 in Part 2, 1 "Hydronic Box Layout".

OPTIMUS PRO Split

6.3 E1 Troubleshooting

6.3.1 Digital display output



6.3.2 Description

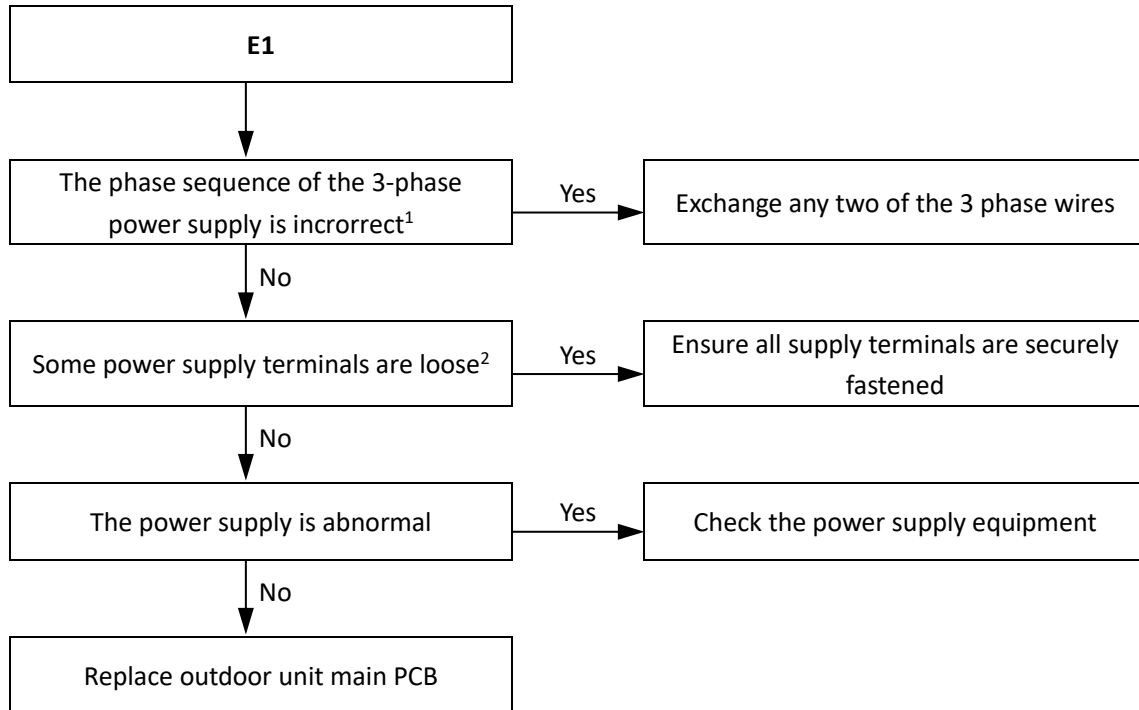
- Phase sequence error.
- Only applies to 3-phase models.
- OPTIMUS PRO Split stops running.

- Error code is displayed on outdoor unit main PCB and user interface.

6.3.3 Possible causes

- Power supply phases not connected in correct sequence.
- Power supply terminals loose.
- Power supply abnormal.
- Main PCB damaged.

6.3.4 Procedure



Notes:

1. The A, B, C terminals of 3-phase power supply should match compressor phase sequence requirements. If the phase sequence is inverted, the compressor will operate inversely. If the wiring connection of each outdoor unit is in A, B, C phase sequence, and multiple units are connected, the current difference between C phase and A, B phases will be very large as the power supply load of each outdoor unit will be on C phase. This can easily lead to tripped circuits and terminal wiring burnout. Therefore if multiple units are to be used, the phase sequence should be staggered, so that the current is distributed among the three phases equally.
2. Loose power supply terminals can cause the compressors to operate abnormally and compressor current to be very large.

OPTIMUS PRO Split

6.4 E2 Troubleshooting

6.4.1 Digital display output



6.4.2 Description

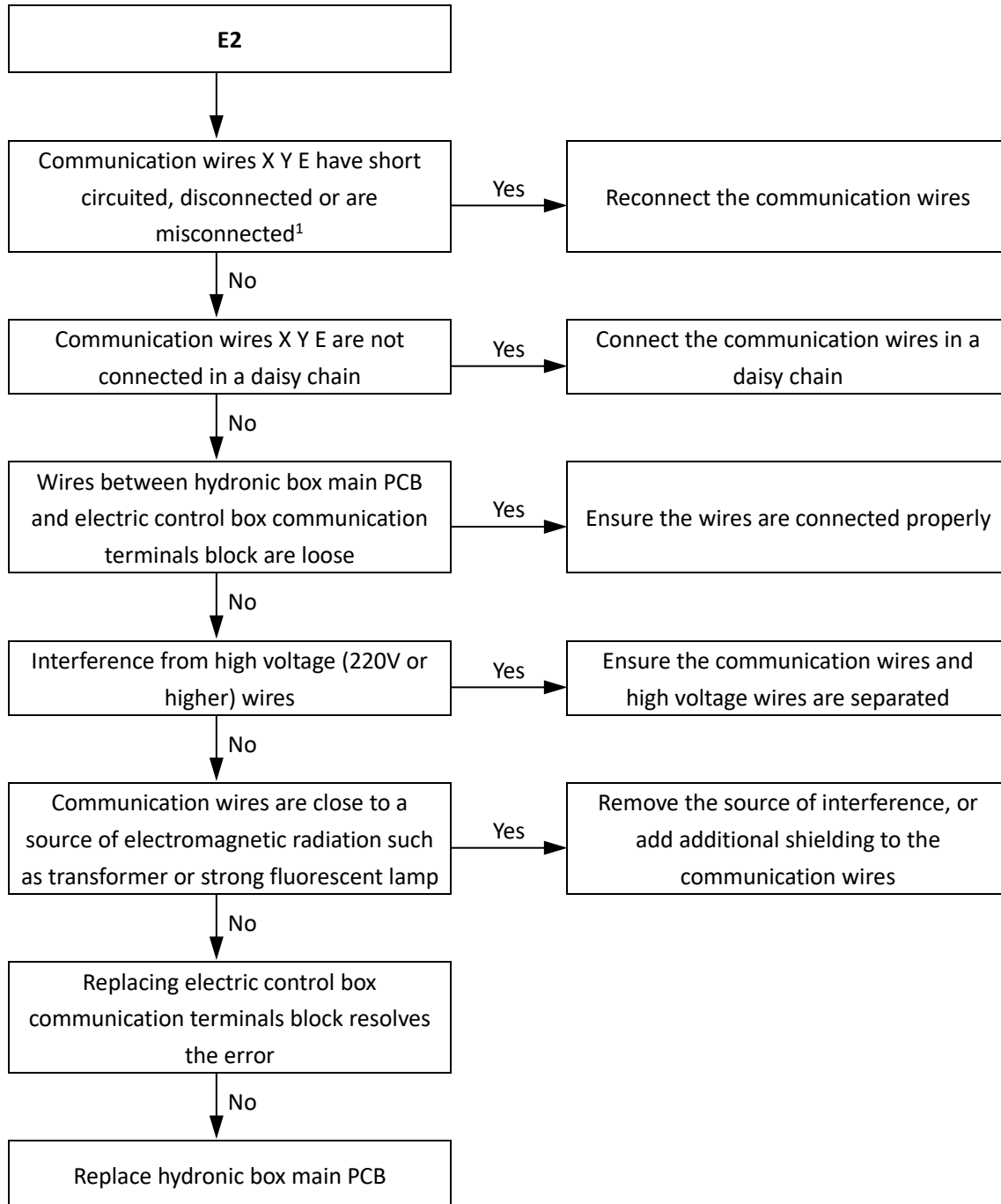
- Communication error between hydronic box and user interface.
- OPTIMUS PRO Split stops running.

- Error code is displayed on hydronic box main PCB and user interface.

6.4.3 Possible causes

- Communication wires between hydronic box and user interface not connected properly.
- Communication wiring X Y E terminals misconnected.
- Loosened wiring within electric control box.
- Interference from high voltage wires or other sources of electromagnetic radiation.
- Damaged main PCB or electric control box communication terminals block.

6.4.4 Procedure



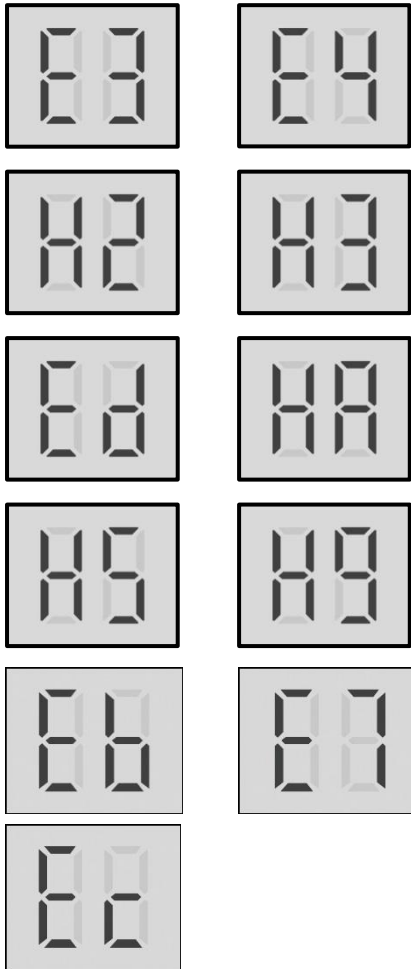
Notes:

1. Measure the resistance among X, Y and E. The normal resistance between X and Y is 120Ω, between X and E is infinite, between Y and E is infinite. Communication wiring has polarity. Ensure that the X wire is connected to X terminals and the Y wire is connected to Y terminals.

OPTIMUS PRO Split

6.5 E3, E4, H2, H3, Ed, HA, H5, H9, Eb, E7, Ec Troubleshooting

6.5.1 Digital display output



6.5.2 Description

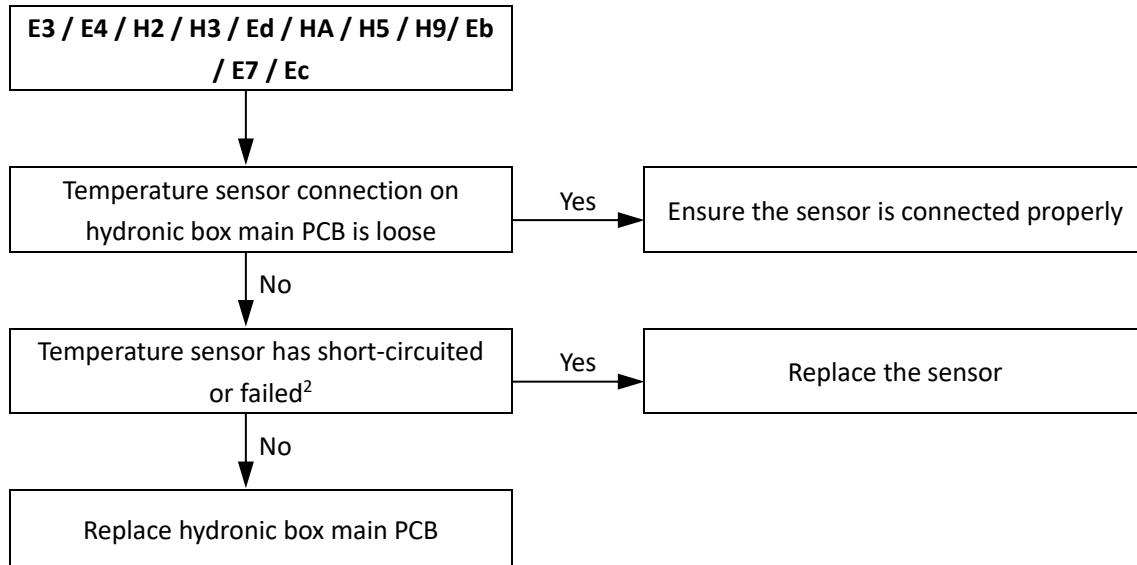
- E3 indicates final outlet water temperature sensor error
- E4 indicates a domestic hot water tank temperature sensor error.
- H2 indicates a water side heat exchanger refrigerant outlet (liquid pipe) temperature sensor error.
- H3 indicates a water side heat exchanger refrigerant inlet (gas pipe) temperature sensor error.
- Ed indicates a water side heat exchanger water inlet temperature sensor error.
- HA indicates a water side heat exchanger water outlet temperature sensor error.
- H5 indicates a room temperature sensor error.
- H9 indicates a circuit 2 water outlet temperature sensor error.
- Eb indicates solar panel temperature sensor error
- E7 indicates balance tank upper temperature sensor error
- Ec indicates balance tank nether temperature sensor error
- OPTIMUS PRO Split stops running.

- Error code is displayed on hydronic box main PCB and user interface.

6.5.3 Possible causes

- Temperature sensor not connected properly or has malfunctioned.
- Damaged hydronic box main PCB.

6.5.4 Procedure



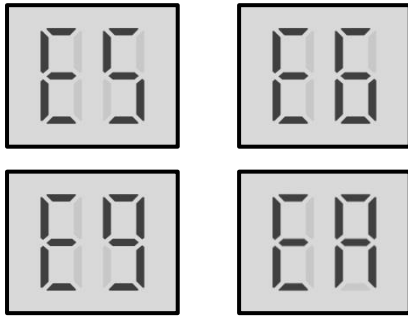
Notes:

- Final water outlet temperature sensor, water side heat exchanger refrigerant inlet (liquid pipe) temperature sensor, water side heat exchanger refrigerant outlet (gas pipe) temperature sensor, water side heat exchanger water inlet temperature sensor and water side heat exchanger water outlet temperature sensor connections are port CN6 on the hydronic box main PCB (labeled 10 in Figure 4-2.1 in Part4, 2.2 "Main PCB for Hydronic System"). Domestic hot water tank temperature sensor connection is port CN13 on the hydronic box main PCB (labeled 13 in Figure 4-2.1 in Part4, 2.2 "Main PCB for Hydronic System"). Circuit 2 water outlet temperature sensor connection is port CN15 on the hydronic box main PCB (labeled 14 in Figure 4-2.1 in Part4, 2.2 "Main PCB for Hydronic System"). Room temperature sensor connection is port CN11 on the hydronic box main PCB (labeled 24 in Figure 4-2.1 in Part4, 2.2 "Main PCB for Hydronic System"). Solar panel temperature sensor connection is port CN18 on the hydronic box main PCB (labeled 15 in Figure 4-2.1 in Part4, 2.2 "Main PCB for Hydronic System"). Balance tank upper temperature sensor connection is port CN24 on the hydronic box main PCB (labeled 11 in Figure 4-2.1 in Part4, 2.2 "Main PCB for Hydronic System") Balance tank nether temperature sensor connection is port CN16 on the hydronic box main PCB (labeled 12 in Figure 4-2.1 in Part4, 2.2 "Main PCB for Hydronic System")
- Measure sensor resistance. If the resistance is too low, the sensor has short-circuited. If the resistance is not consistent with the sensor's resistance characteristics table, the sensor has failed. Refer to Table 4-5.1 or 4-5.3 in Part 4, 5.1 "Temperature Sensor Resistance Characteristics".

OPTIMUS PRO Split

6.6 E5, E6, E9, EA Troubleshooting

6.6.1 Digital display output



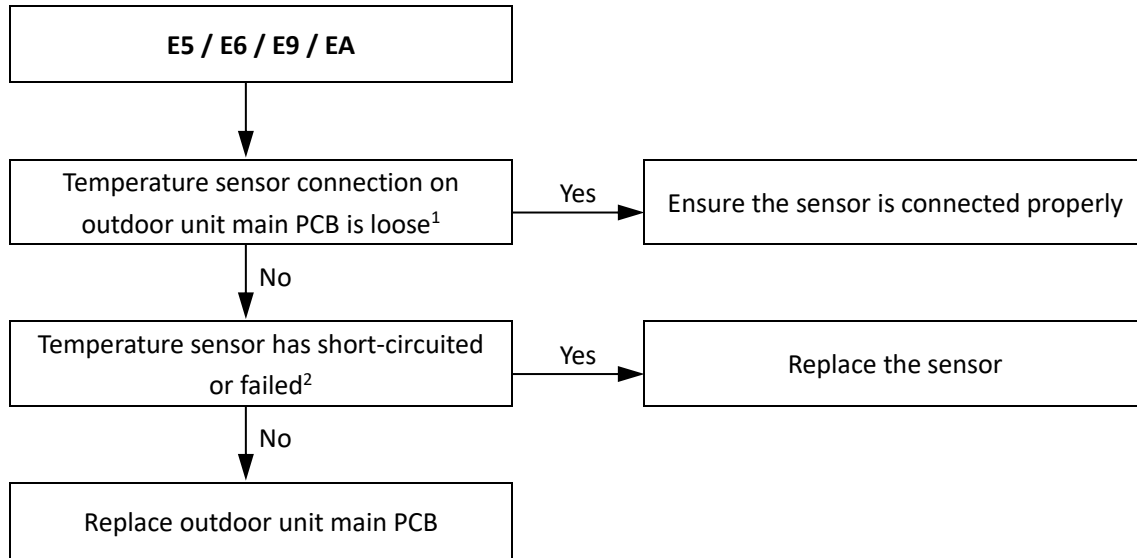
6.6.2 Description

- E5 indicates an air side heat exchanger refrigerant outlet temperature sensor error.
- E6 indicates an outdoor ambient temperature sensor error.
- E9 indicates a suction pipe temperature sensor error.
- EA indicates a discharge temperature sensor error.
- OPTIMUS PRO Split stops running.
- Error code is displayed on outdoor unit main PCB and user interface.

6.6.3 Possible causes

- Temperature sensor not connected properly or has malfunctioned.
- Damaged outdoor unit main PCB.

6.6.4 Procedure



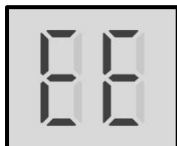
Notes:

1. Air side heat exchanger refrigerant outlet temperature sensor and outdoor ambient temperature sensor connections are port CN9 on the HOP4(6,8,10)WODU outdoor unit refrigerant system main PCB (labeled 12 in Figure 4-2.2 in Part 4, 2.1 "Main PCBs for Refrigerant System, Inverter Module"), port CN9 on the HOP12(14,16)WODU outdoor unit refrigerant system main PCB (labeled 12 in Figure 4-2.3 in Part 4, 2.1 "Main PCBs for Refrigerant System, Inverter Module"), port CN9 on the HOP12(14,16)WODU3 outdoor unit refrigerant system main PCB (labeled 17 in Figure 4-2.4 in Part 4, 2.1 "Main PCBs for Refrigerant System, Inverter Module"). Discharge pipe temperature sensor connection are port CN8 on the HOP4(6,8,10)WODU outdoor unit refrigerant system main PCB (labeled 15 in Figure 4-2.2 in Part 4, 2.1 "Main PCBs for Refrigerant System, Inverter Module"), port CN8 on the HOP12(14,16)WODU outdoor unit refrigerant system main PCB (labeled 15 in Figure 4-2.3 in Part 4, 2.1 "Main PCBs for Refrigerant System, Inverter Module"), port CN4 on the HOP12(14,16)WODU3 outdoor unit refrigerant system main PCB (labeled 15 in Figure 4-2.4 in Part 4, 2.1 "Main PCBs for Refrigerant System, Inverter Module"). Suction pipe temperature sensor connection are port CN1 on the HOP4(6,8,10)WODU outdoor unit refrigerant system main PCB (labeled 14 in Figure 4-2.2 in Part 4, 2.1 "Main PCBs for Refrigerant System, Inverter Module"), port CN1 on the HOP12(14,16)WODU outdoor unit refrigerant system main PCB (labeled 14 in Figure 4-2.3 in Part 4, 2.1 "Main PCBs for Refrigerant System, Inverter Module"), port CN8 on the HOP12(14,16)WODU3 outdoor unit refrigerant system main PCB (labeled 16 in Figure 4-2.4 in Part 4, 2.1 "Main PCBs for Refrigerant System, Inverter Module").
2. Measure sensor resistance. If the resistance is too low, the sensor has short-circuited. If the resistance is not consistent with the sensor's resistance characteristics table, the sensor has failed. Refer to Table 4-5.1, and Table 4-5.2 in Part 4, 5.1 "Temperature Sensor Resistance Characteristics".

OPTIMUS PRO Split

6.7 EE Troubleshooting

6.7.1 Digital display output



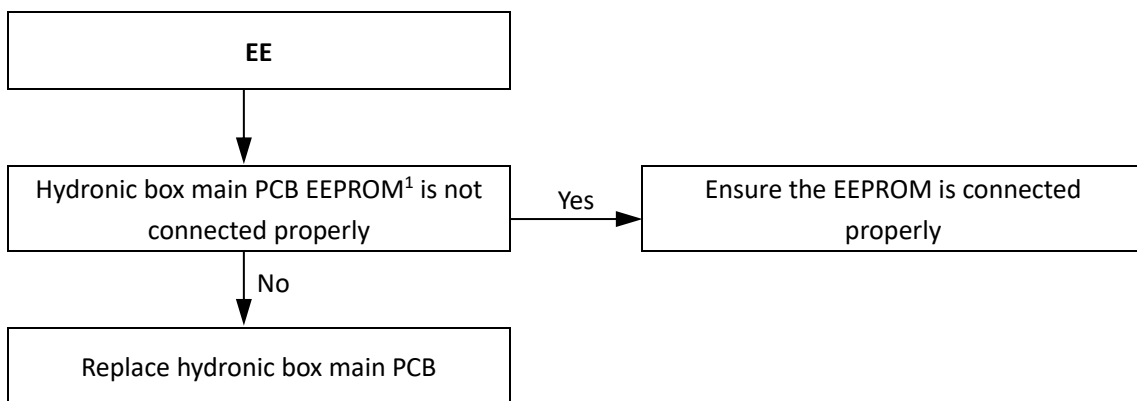
6.7.2 Description

- Hydronic box main PCB EEPROM error.
- OPTIMUS PRO Split stops running.
- Error code is displayed on hydronic box main PCB and user interface.

6.7.3 Possible causes

- Hydronic box main PCB EEPROM is not connected properly.
- Hydronic box main PCB damaged.

6.7.4 Procedure



Notes:

- Hydronic box main PCB EEPROM is designated IC39 on the main PCB for hydronic box (labeled 31 in Figure 4-2.1 in Part4, 2.2 "Main PCB for Hydronic System").

6.8 F1 Troubleshooting

6.8.1 Digital display output



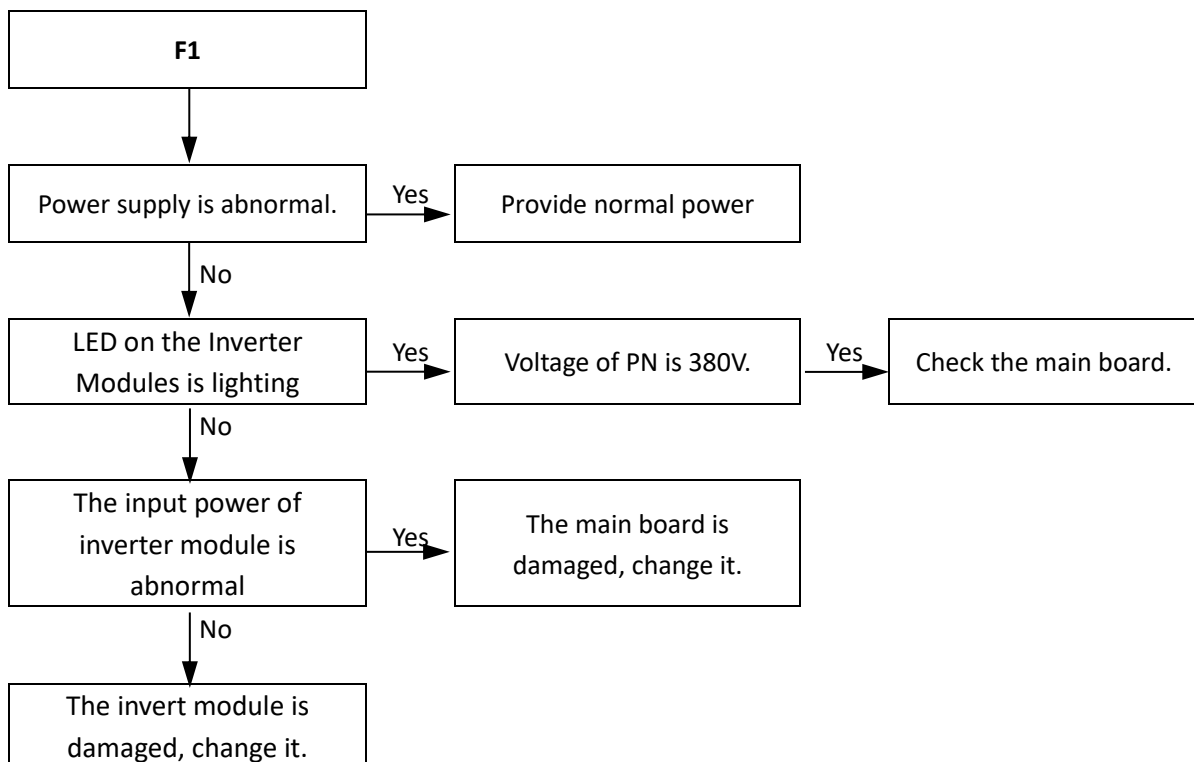
6.8.2 Description

- Low DC generatrix voltage.
- OPTIMUS PRO Split stops running.
- Error code is displayed on hydronic system main PCB and user interface.

6.8.3 Possible causes

- The DC generatrix voltage is too low.

6.8.4 Procedure



OPTIMUS PRO Split

6.9 HF Troubleshooting

6.9.1 Digital display output



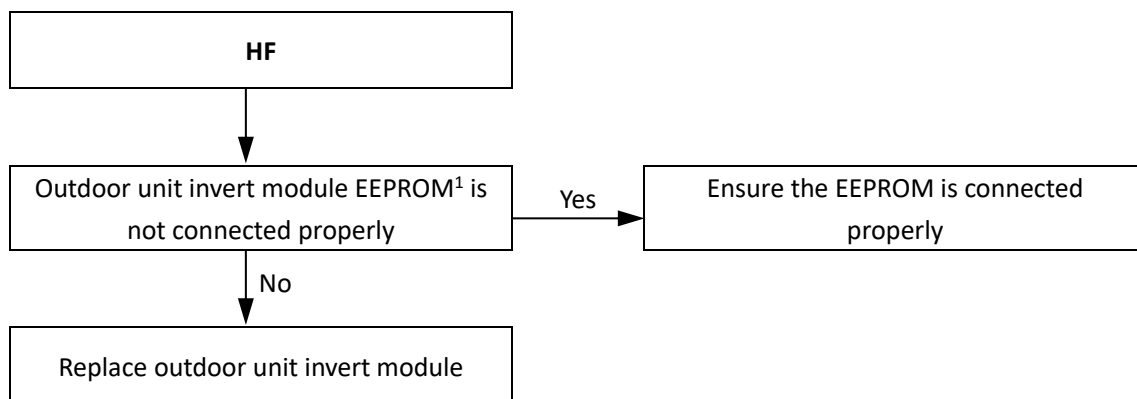
6.9.2 Description

- Outdoor unit inverter module EEPROM error.
- OPTIMUS PRO Split stops running.
- Error code is displayed on outdoor unit main PCB and user interface.

6.9.3 Possible causes

- Outdoor unit invert module EEPROM is not connected properly.
- Outdoor unit invert module EEPROM damaged.

6.9.4 Procedure



Notes:

1. Outdoor unit invert module EEPROM is designated IC320 on the HOP4(6,8,10)WODU outdoor unit invert module (labeled 9 in Figure 4-2.5 in Part4, 2.3 "Main PCBs for Refrigerant System, Inverter Module"), designated IC14 on the HOP12(14,16)WODU outdoor unit invert module (labeled 11 in Figure 4-2.6 in Part4, 2.3 "Main PCBs for Refrigerant System, Inverter Module"), designated IC25 on the HOP12(14,16)WODU3 outdoor unit invert module (labeled 14 in Figure 4-2.7 in Part4, 2.3 "Main PCBs for Refrigerant System, Inverter Module").

6.10 H0 Troubleshooting

6.10.1 Digital display output



6.10.2 Description

- Communication error between outdoor unit and hydronic box.
- OPTIMUS PRO Split stops running.

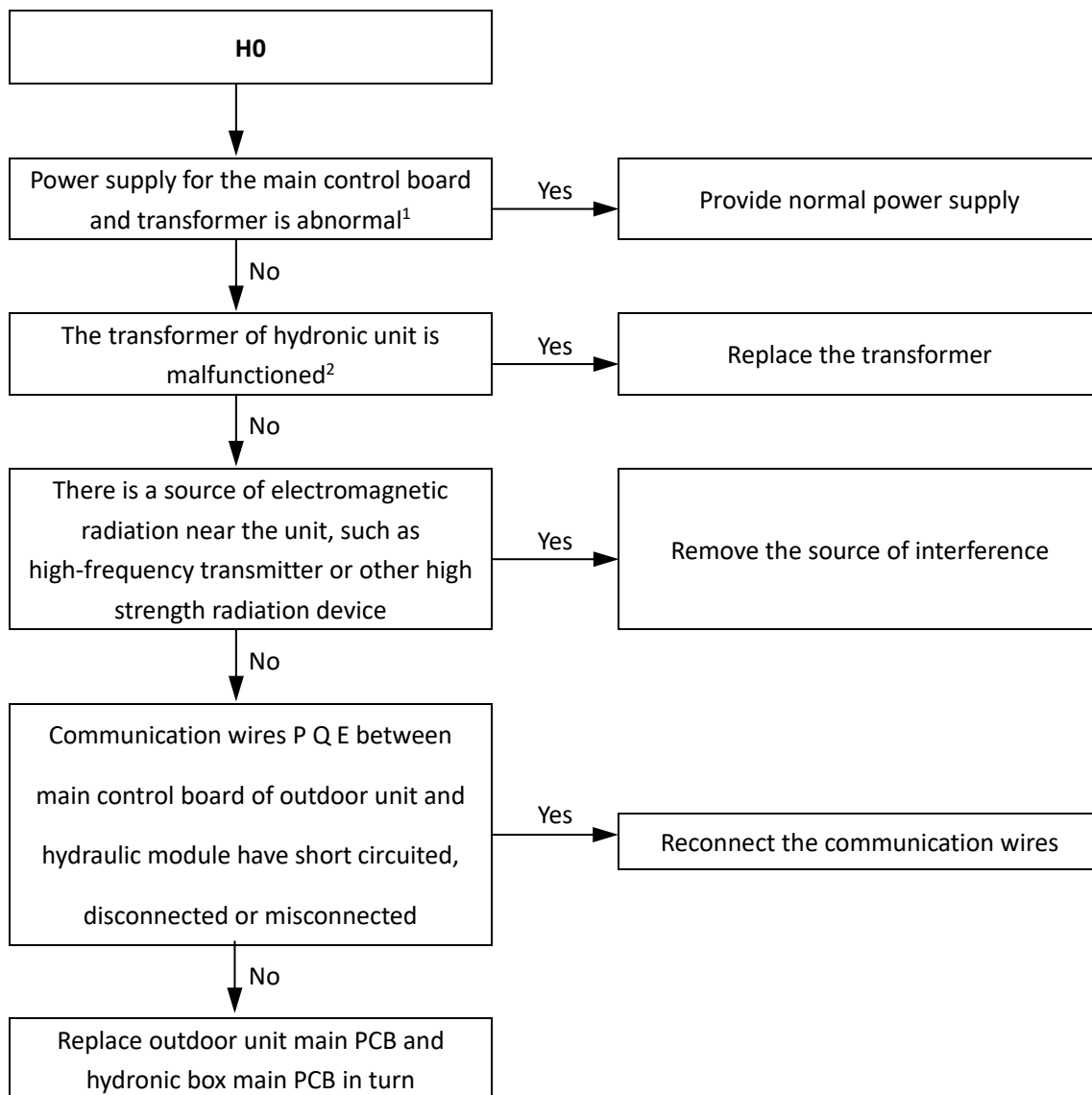
- Error code is displayed on hydronic box main PCB, outdoor unit main PCB and user interface.

6.10.3 Possible causes

- Power supply abnormal.
- Transformer malfunction.
- Interference from a source of electromagnetic radiation.
- Outdoor unit main PCB or hydronic box main PCB damaged.

OPTIMUS PRO Split

6.10.4 Procedure



Notes:

1. Measure the voltages of transformer input port and out port. The input voltage of transformer is 220V AC, output voltage of transformer is 13.5V AC. If any voltages is abnormal, the power supply for the main control board of hydraulic module and transformer will be abnormal.
2. Measure the voltages of transformer output port ports. If the voltages are not normal, the transformer has malfunctioned.

6.11 H1 Troubleshooting

6.11.1 Digital display output



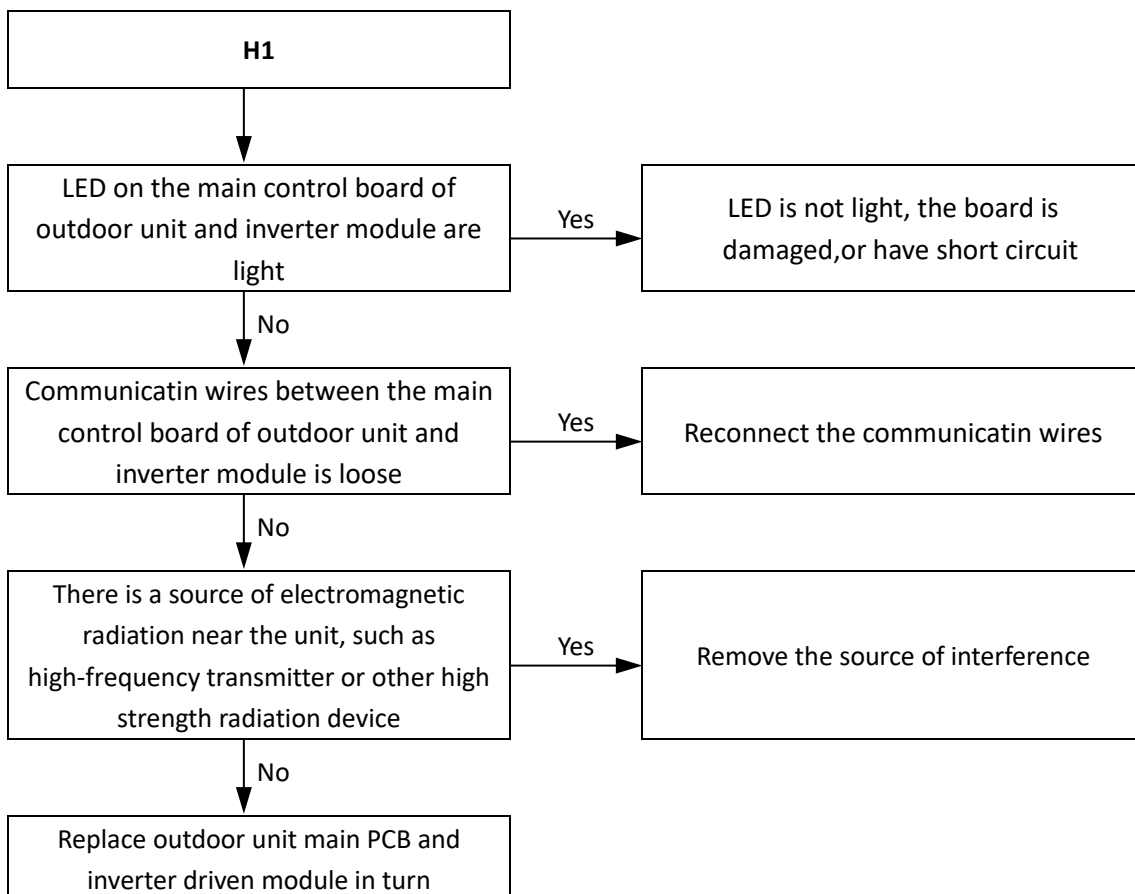
6.11.2 Description

- Communication error between outdoor unit main control board and inverter module.
- OPTIMUS PRO Split stops running.
- Error code is displayed on outdoor unit main PCB and user interface.

6.11.3 Possible causes

- Power supply abnormal.
- Interference from a source of electromagnetic radiation.
- Outdoor unit main PCB or inverter driven module damaged.

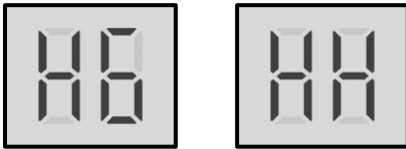
6.11.4 Procedure



OPTIMUS PRO Split

6.12 H6, HH Troubleshooting

6.12.1 Digital display output



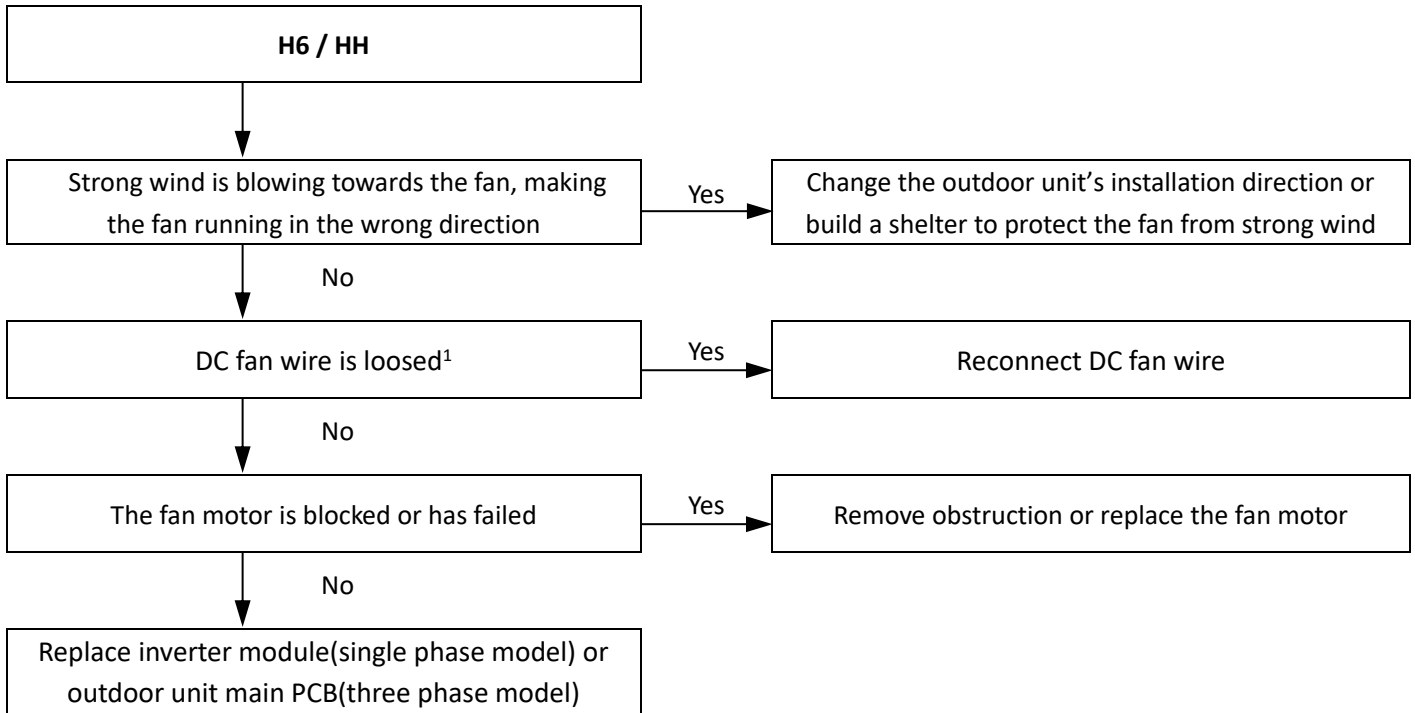
6.12.2 Description

- H6 indicates a DC fan error.
- HH indicates that H6 protection has occurred 10 times in 2 hours. When HH error occurs, a manual system restart is required before the system can resume operation. The cause of HH error should be addressed promptly in order to avoid system damage.
- OPTIMUS PRO Split stops running.
- Error code is displayed on outdoor unit main PCB and user interface.

6.12.3 Possible causes

- DC fan wire is loosed.
- High wind speed.
- Fan motor blocked or has failed.
- Invert module damaged.
- Main PCB is damaged.

6.12.4 Procedure



Notes:

1. Refer to Figures 4-1.1 to 4-1.4 in Part 4, 1.1 "Outdoor Unit Electric Control Box Layout" and to the OPTIMUS PRO Split Engineering Data Book, Part 4 "Wiring Diagrams".
2. Measure the voltage between the DC fan motor power supply's white and black wires. The normal voltage is 15V when the unit is in standby. If the voltage is significantly different from 15V, the IPM module on the inverter module is damaged. DC fan connection are port CN19 on the HOP4(6,8,10)WODU outdoor unit inverter module PCB (labeled 5 in Figure 4-2.5 in Part4, 2.3 "Main PCB for Refrigerant System, Inverter Module"). port CN19 on the HOP12(14,16)WODU outdoor unit inverter module PCB (labeled 4 in Figure 4-2.6 in Part 4, 2. 3 "Main PCB for Refrigerant System, Inverter Module"), port CN109 on the HOP12(14,16)WODU3 outdoor unit refrigerant system main PCB (labeled 30 in Figure 4-2.4 in Part 4, 2. 3 "Main PCB for Refrigerant System, Inverter Module").

OPTIMUS PRO Split

6.13 H7 Troubleshooting

6.13.1 Digital display output



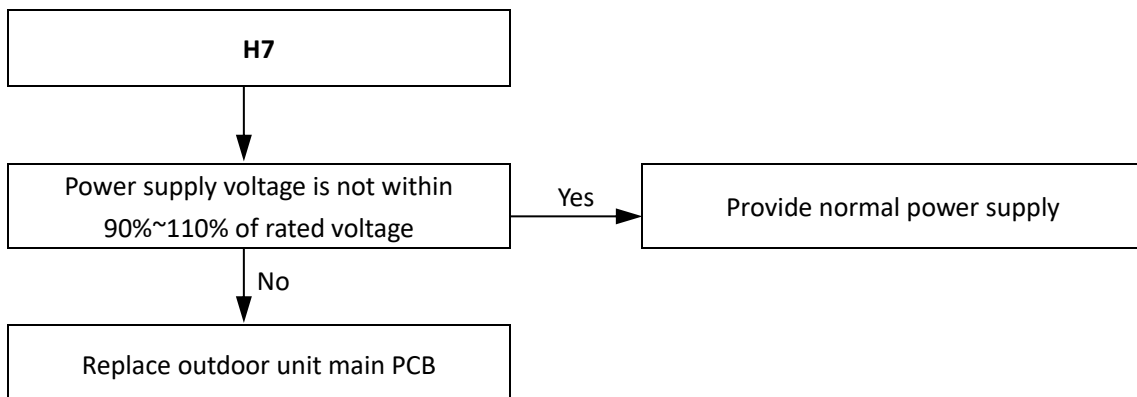
6.13.2 Description

- Abnormal main circuit voltage.
- OPTIMUS PRO Split stops running.
- Error code is displayed on outdoor unit main PCB and user interface.

6.13.3 Possible causes

- Power supply voltage not within 90%~110% of rated voltage.
- Outdoor unit main PCB is damaged.

6.13.4 Procedure



6.14 H8 Troubleshooting

6.14.1 Digital display output



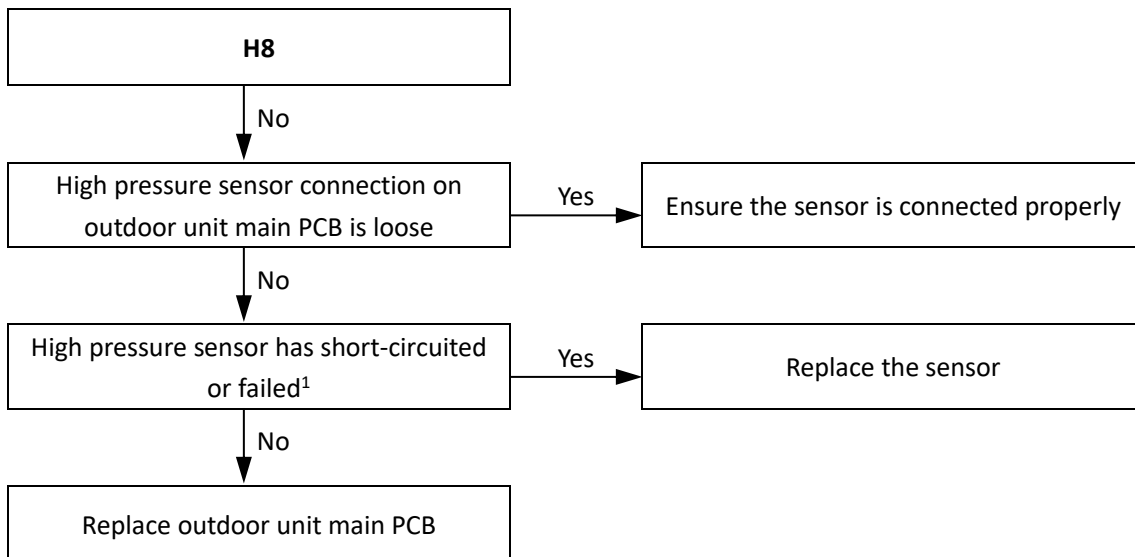
6.14.2 Description

- Pressure sensor error.
- OPTIMUS PRO Split stops running.
- Error code is displayed on outdoor unit main PCB and user interface.

6.14.3 Possible causes

- Pressure sensor not connected properly or has malfunctioned.
- Outdoor unit main PCB is damaged.

6.14.4 Procedure



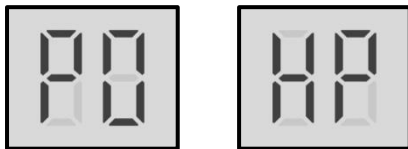
Notes:

1. Measure the resistance among the three terminals of the pressure sensor. If the resistance is of the order of mega Ohms or infinite, the pressure sensor has failed. The pressure sensor connection are port CN4 on the HOP4(6,8,10)WODU outdoor unit refrigerant system main PCB (labeled 19 in Figure 4-2.2 in Part 4, 2.3 "Main PCB for Refrigerant System, Inverter Module"). port CN4 on the HOP12(14,16)WODU outdoor unit refrigerant system main PCB (labeled 19 in Figure 4-2.3 in Part 4, 2.3 "Main PCB for Refrigerant System, Inverter Module"), port CN6 on the HOP12(14,16)WODU3 outdoor unit refrigerant system main PCB (labeled 13 in Figure 4-2.4 in Part 4, 2.3 "Main PCB for Refrigerant System, Inverter Module").

OPTIMUS PRO Split

6.15 P0, HP Troubleshooting

6.15.1 Digital display output



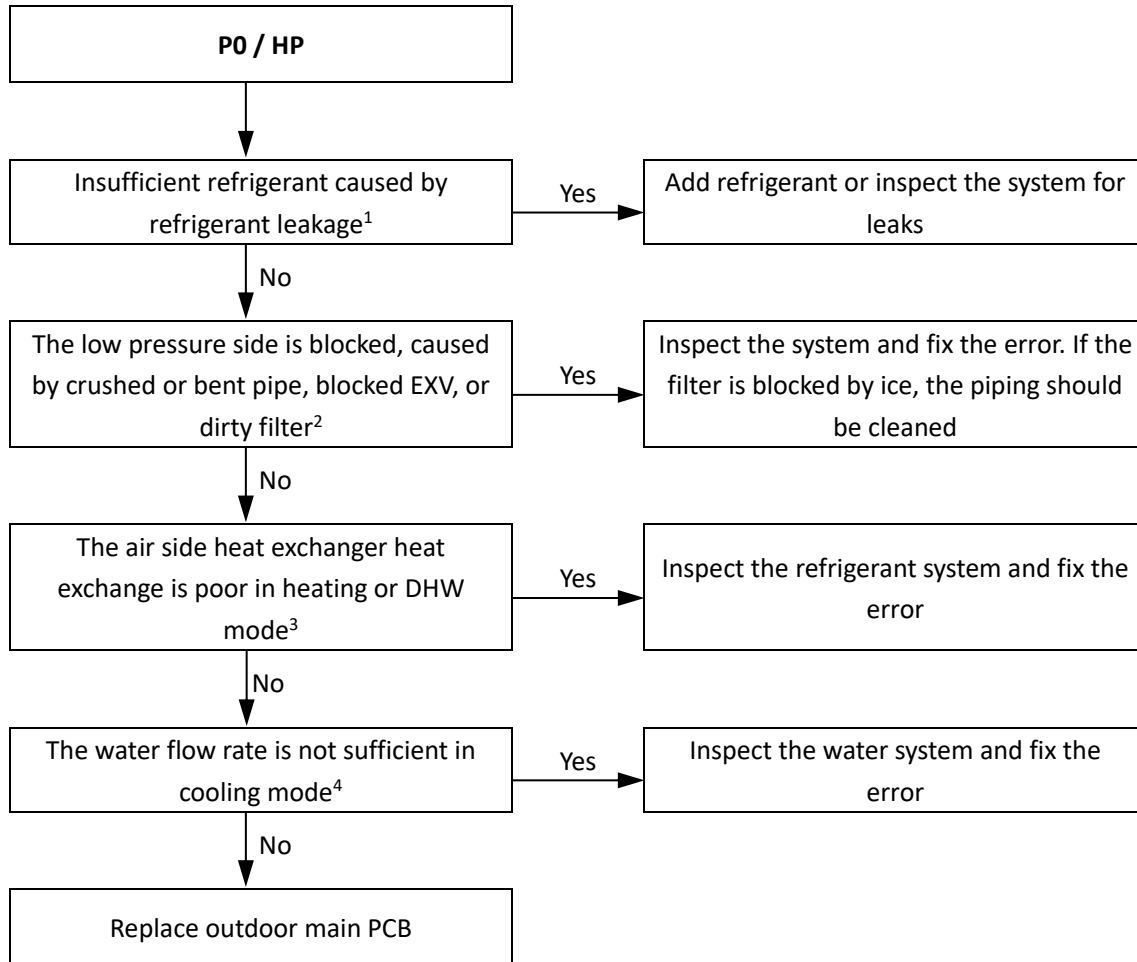
6.15.2 Description

- P0 indicates suction pipe low pressure protection. When the suction pressure falls below 0.14MPa, the system displays P0 protection and OPTIMUS PRO Split stops running. When the pressure rises above 0.3MPa, P0 is removed and normal operation resumes.
- HP indicates $P_e < 0.6\text{Mpa}$ occurred 3 times in an hour.
- Error code is displayed on outdoor unit main PCB and user interface.

6.15.3 Possible causes

- Low pressure switch not connected properly or has malfunctioned.
- Insufficient refrigerant.
- Low pressure side blockage.
- Poor evaporator heat exchange in heating mode or DHW mode.
- Insufficient water flow in cooling mode.
- Outdoor unit main PCB damaged.

6.15.4 Procedure



Notes:

1. To check for insufficient refrigerant:
An insufficiency of refrigerant causes compressor discharge temperature to be higher than normal, discharge and suction pressures to be lower than normal and compressor current to be lower than normal, and may cause frosting to occur on the suction pipe. These issues disappear once sufficient refrigerant has been charged into the system.
2. A low pressure side blockage causes compressor discharge temperature to be higher than normal, suction pressure to be lower than normal and compressor current to be lower than normal, and may cause frosting to occur on the suction pipe. For normal system parameters.
3. Check air side heat exchanger, fan and air outlets for dirt/blockages.
4. Check water side heat exchanger, water piping, circulator pumps and water flow switch for dirt/blockages.

OPTIMUS PRO Split

6.16 P1 Troubleshooting

6.16.1 Digital display output



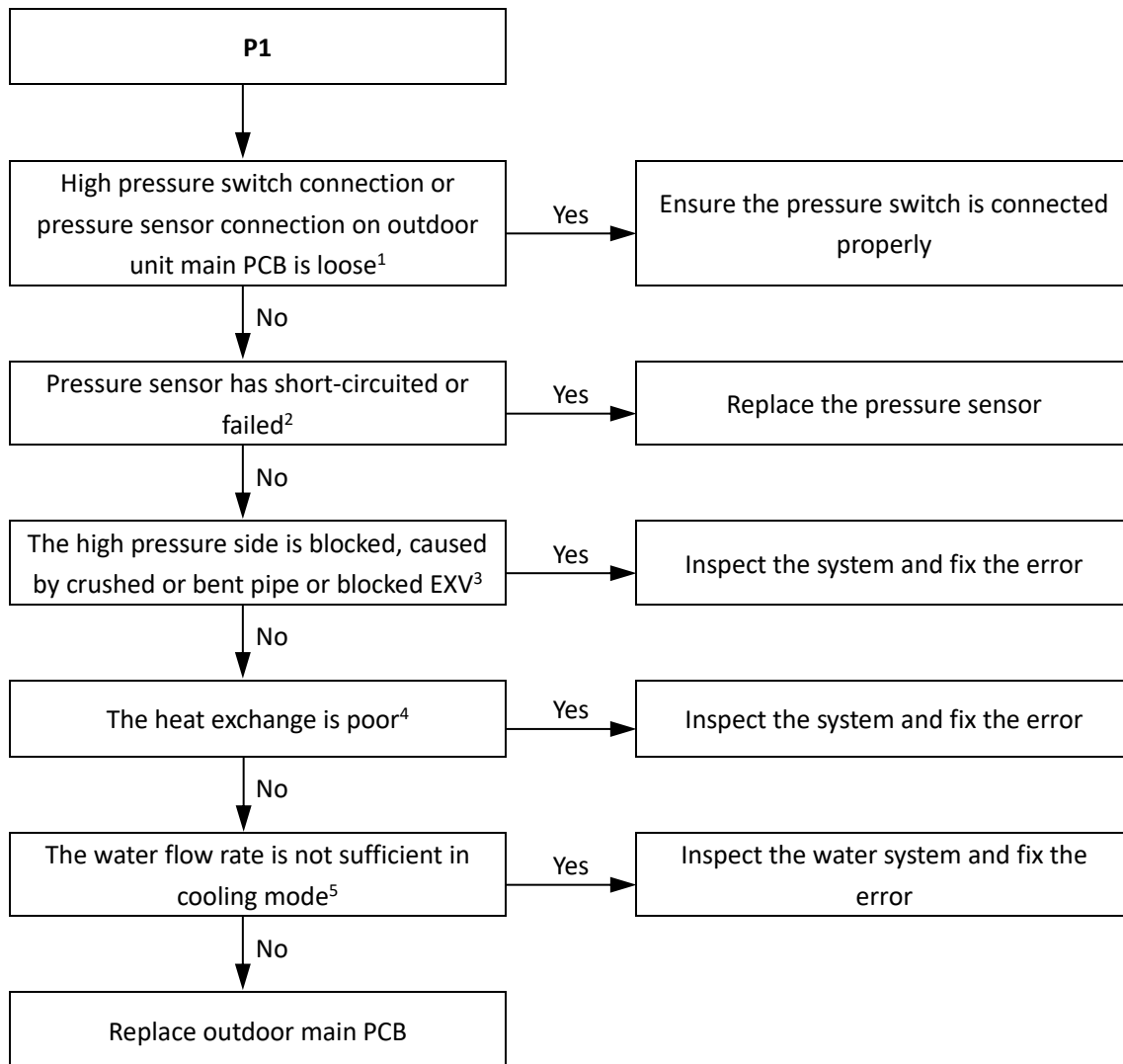
6.16.2 Description

- Discharge pipe high pressure protection. When the discharge pressure rises above 4.3MPa, the system displays P1 protection and OPTIMUS PRO Split stops running. When the discharge pressure falls below 3.6MPa, P1 is removed and normal operation resumes.
- Error code is displayed on outdoor unit main PCB and user interface.

6.16.3 Possible causes

- Pressure sensor/switch not connected properly or has malfunctioned.
- Excess refrigerant.
- System contains air or nitrogen.
- High pressure side blockage.
- Poor condenser heat exchange.
- Outdoor unit main PCB damaged.

6.16.4 Procedure



Notes:

1. High pressure switch connection is port CN13 on the HOP4(6,8,10)WODU outdoor unit refrigerant system main PCB (labeled 16 in Figure 4-2.2 in Part4, 2.3 "Main PCB for Refrigerant System, Inverter Module"). port CN13 on the HOP12(14,16)WODU outdoor unit refrigerant system main PCB (labeled 16 in Figure 4-2.3 in Part 4, 2. 3 "Main PCB for Refrigerant System, Inverter Module"), port CN31 on the HOP12(14,16)WODU3 outdoor unit refrigerant system main PCB (labeled 20 in Figure 4-2.4 in Part 4, 2. 3 "Main PCB for Refrigerant System, Inverter Module").
2. Measure the resistance among the three terminals of the pressure sensor. If the resistance is of the order of mega Ohms or infinite, the pressure sensor has failed.
3. High pressure side blockage causes discharge temperature to be higher than normal, discharge pressure to be higher than normal and suction pressure to be lower than normal.
4. In heating mode check water side heat exchanger, water piping, circulator pumps and water flow switch for dirt/blockages. In cooling mode check air side heat exchanger, fan(s) and air outlets for dirt/blockages.
5. Check water pressure on the manometer. If the water pressure is not > 1 bar, water flow is insufficient. Refer to Figure 2-1.9 in Part 2, 1.2 "Hydronic Box Layout".

OPTIMUS PRO Split

6.17 P3 Troubleshooting

6.17.1 Digital display output



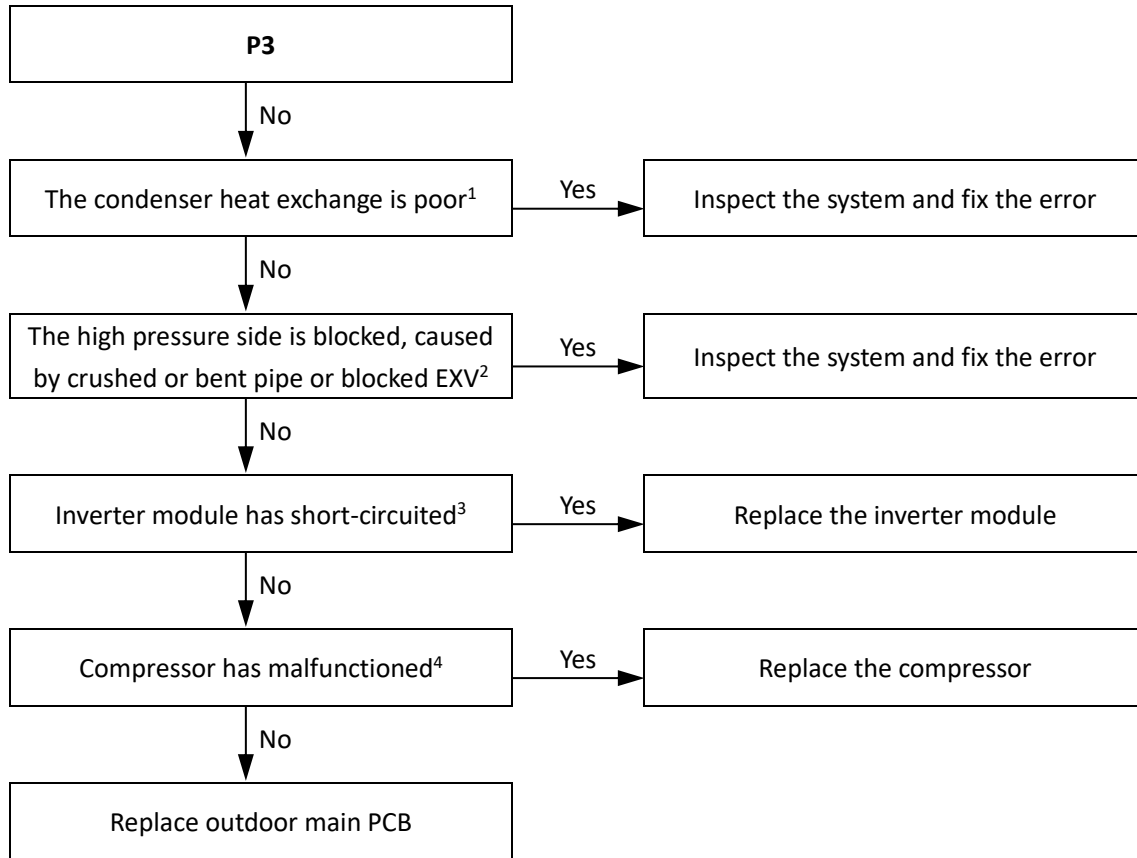
6.17.2 Description

- Compressor current protection.
- When the compressor current rises above the protection value (4/6kW models 18A, 8/10kW model 19A, 12/14/16kW single phase model 30A, 12/14/16kW three phase model 14A,), the system displays P3 protection and OPTIMUS PRO Split stops running. When the current returns to the normal range, P3 is removed and normal operation resumes.
- Error code is displayed on refrigerant system main PCB and user interface.

6.17.3 Possible causes

- Poor condenser heat exchange.
- High pressure side blockage.
- Inverter module damaged.
- Compressor damaged.
- Outdoor unit main PCB damaged.

6.17.4 Procedure



Notes:

1. In heating mode check water side heat exchanger, water piping, circulator pumps and water flow switch for dirt/blockages. In cooling mode check air side heat exchanger, fan and air outlets for dirt/blockages.
2. High pressure side blockage causes discharge temperature to be higher than normal, discharge pressure to be higher than normal and suction pressure to be lower than normal.
3. Set a multi-meter to buzzer mode and test any two terminals of P N and U V W of the inverter module. If the buzzer sounds, the inverter module has short-circuited.
4. The normal resistances of the inverter compressor are 0.7-1.5Ω among U V W and infinite between each of U V W and ground. If any of the resistances differ from these specifications, the compressor has malfunctioned.

OPTIMUS PRO Split

6.18 P4 Troubleshooting

6.18.1 Digital display output



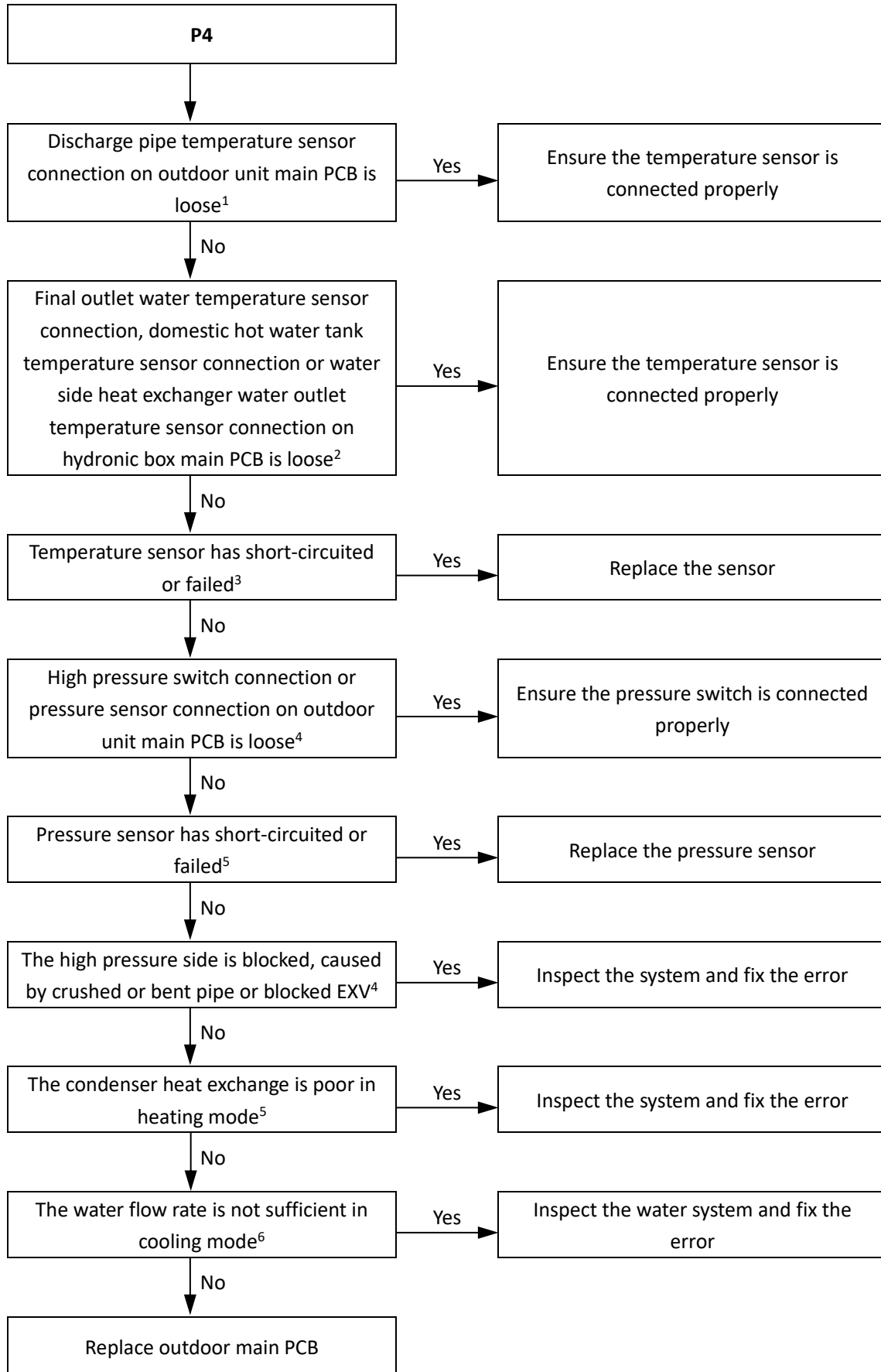
6.18.2 Description

- Discharge temperature protection.
- When the compressor the discharge temperature rises above 115°C, the system displays P4 protection and OPTIMUS PRO Split stops running. When the discharge temperature falls below 95°C, P4 is removed and normal operation resumes.
- Error code is displayed on refrigerant system main PCB and user interface.

6.18.3 Possible causes

- Temperature sensor error
- High pressure side blockage.
- Poor condenser heat exchange.
- Outdoor unit main PCB damaged.

6.18.4 Procedure



Notes:

1. Discharge pipe temperature sensor connection is port CN8 on the HOP4(6,8,10)WODU outdoor unit refrigerant system main PCB (labeled 15 in Figure 4-2.2 in Part4, 2.3 "Main PCB for Refrigerant System, Inverter Module"). port CN8 on the HOP12(14,16)WODU outdoor unit refrigerant

OPTIMUS PRO Split

system main PCB (labeled 15 in Figure 4-2.3 in Part 4, 2. 3 "Main PCB for Refrigerant System, Inverter Module"), port CN4 on the

HOP12(14,16)WODU3 outdoor unit refrigerant system main PCB (labeled 15 in Figure 4-2.4 in Part 4, 2. 3 "Main PCB for Refrigerant System, Inverter Module").

2. Final outlet water temperature sensor and water side heat exchanger water outlet temperature sensor connections are port CN6 on the hydronic box main PCB (labeled 10 in Figure 4-2.1 in Part4, 2.2 "Main PCB for Hydronic System"). Domestic hot water tank temperature sensor connection is port CN13 on hydronic box main PCB (labeled 13 in Figure 4-2.1 in Part4, 2.2 "Main PCB for Hydronic System").
3. Measure sensor resistance. If the resistance is too low, the sensor has short-circuited. If the resistance is not consistent with the sensor's resistance characteristics table, the sensor has failed. Refer to Part 2, 1 "Layout of Functional Components" and to Table 5-5.1 or 5-5.2 in Part 5, 5.1 "Temperature Sensor Resistance Characteristics".
4. High pressure switch connection is port CN13 on the HOP4(6,8,10)WODU outdoor unit refrigerant system main PCB (labeled 16 in Figure 4-2.2 in Part4, 2.3 "Main PCB for Refrigerant System, Inverter Module"). port CN13 on the HOP12(14,16)WODU outdoor unit refrigerant system main PCB (labeled 16 in Figure 4-2.3 in Part 4, 2. 3 "Main PCB for Refrigerant System, Inverter Module"), port CN31 on the HOP12(14,16)WODU3 outdoor unit refrigerant system main PCB (labeled 20 in Figure 4-2.4 in Part 4, 2. 3 "Main PCB for Refrigerant System, Inverter Module").
5. Measure the resistance among the three terminals of the pressure sensor. If the resistance is of the order of mega Ohms or infinite, the pressure sensor has failed.
6. High pressure side blockage causes discharge temperature to be higher than normal, discharge pressure to be higher than normal and suction pressure to be lower than normal.
7. Check air side heat exchanger, fan and air outlets for dirt/blockages.
8. Check the water side heat exchanger, water piping, circulator pumps and water flow switch for dirt/blockages.

6.19 P5 Troubleshooting

6.19.1 Digital display output



6.19.2 Description

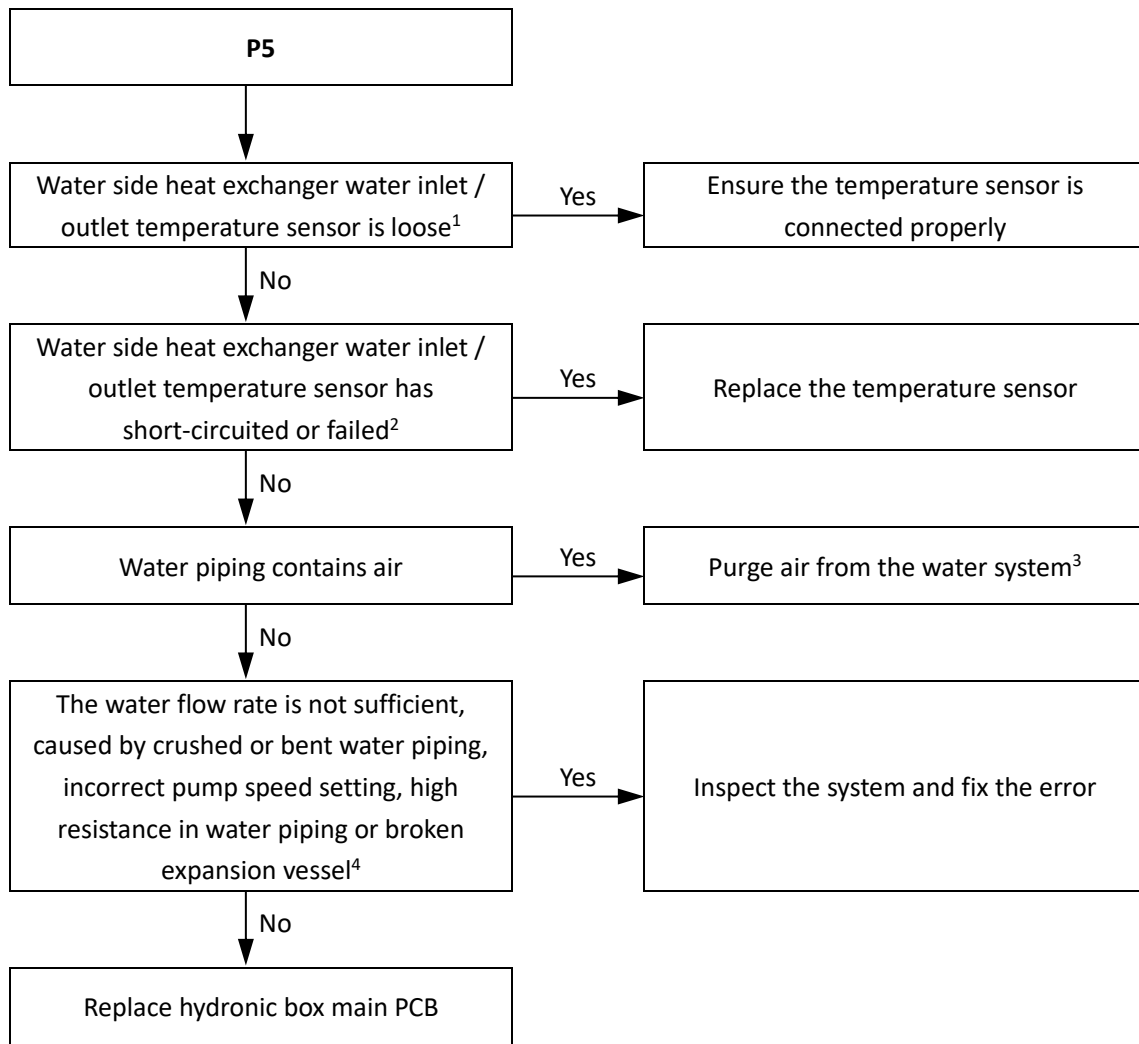
- High temperature difference between water side heat exchanger water inlet and water outlet temperatures protection.
- OPTIMUS PRO Split stops running.
- Error code is displayed on hydronic box main PCB and user interface.

6.19.3 Possible causes

- Temperature sensor not connected properly or has malfunctioned.
- Water piping contains air.
- Insufficient water flow.
- Hydronic box main PCB damaged.

OPTIMUS PRO Split

6.19.4 Procedure

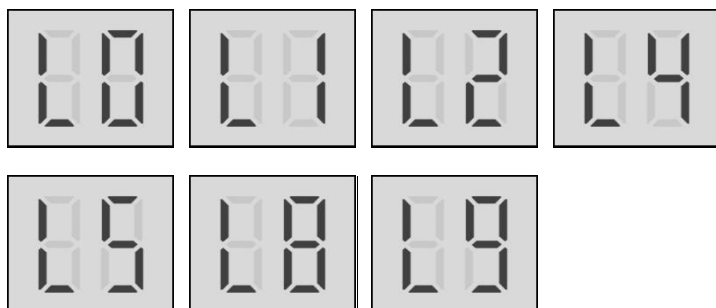


Notes:

1. Water side heat exchanger water inlet temperature sensor and water side heat exchanger water outlet temperature sensor connections are port CN6 on the hydronic box main PCB (labeled 10 in Figure 4-2.1 in Part 4, 2.2 "Main PCB for Hydronic System").
2. Measure sensor resistance. If the resistance is too low, the sensor has short-circuited. If the resistance is not consistent with the sensor's resistance characteristics table, the sensor has failed. Refer to Part 2, 1.2 "Hydronic Box Layout" and to Table 5-5.3 in Part 5, 5.1 "Temperature Sensor Resistance Characteristics".
3. Refer to the OPTIMUS PRO Split Engineering Data Book, Part 5, 15 "SPECIAL FUNCTIONS".
4. Check water pressure on the manometer. If the water pressure is not > 1 bar, water flow is insufficient. Refer to Figures 2-1.7 and 2-1.8 in Part 2, 1.2 "Hydronic Box Layout".

6.20 Inverter module Troubleshooting for single-phase models

6.20.1 Digital display output



6.20.2 Description

- Inverter module protection.
- OPTIMUS PRO Split stops running.
- Specific error code L0, L1, L2, L4, L5, L8, L9 is displayed on the user interface and the main control board of refrigerant system.

6.20.3 Possible causes

- Inverter module protection.
- DC bus low or high voltage protection.
- MCE error(DC bus low or high voltage protection or software over current protection)
- Zero speed protection.
- Excessive compressor frequency variation.
- Actual compressor frequency differs from target frequency.
- High pressure protection.
- PED board self checking fail.

6.20.4 Specific error codes for inverter module protection

Table 4-4.1: Specific error codes

Specific error code	Content
L0	Inverter module protection
L1	DC bus low voltage protection
L2	DC bus high voltage protection
L4	MCE error(DC bus low or high voltage protection or software over current protection)
L5	Zero speed protection
L8	Compressor frequency variation greater than 15Hz within 1 second protection
L9	Actual compressor frequency differs from target frequency by more than 15Hz protection

OPTIMUS PRO Split

The specific error codes can also be obtained from the LED indicators on the inverter module.

Table 4-4.2: Errors indicated on LED, single-phase 4~10kW

LED301 flashing pattern (GREEN) LED302 is always on (RED)	Corresponding error
Flashes 8 times and stops for 1 second, then repeats	L0 - Inverter module protection
Flashes 9 times and stops for 1 second, then repeats	L1 - DC bus low voltage protection
Flashes 10 times and stops for 1 second, then repeats	L2 - DC bus high voltage protection
Flashes 12 times and stops for 1 second, then repeats	L4 - MCE error
Flashes 13 times and stops for 1 second, then repeats	L5 - Zero speed protection
Flashes 16 times and stops for 1 second, then repeats	L8 - Compressor frequency variation greater than 15Hz within one second protection
Flashes 17 times and stops for 1 second, then repeats	L9 - Actual compressor frequency differs from target frequency by more than 15Hz protection

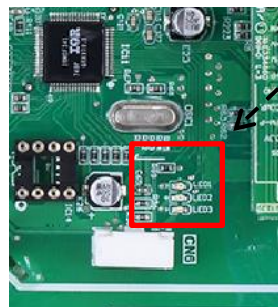
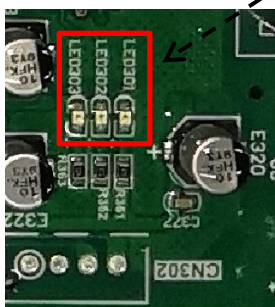
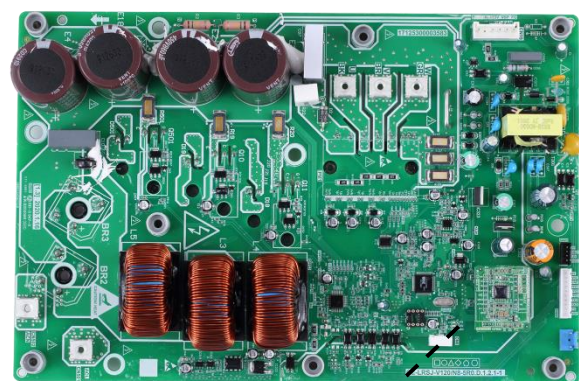
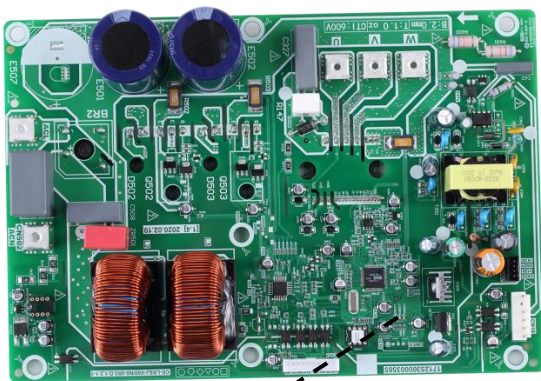
Table 4-4.3: Errors indicated on LED, single-phase 4~10kW

LED1 flashing pattern (GREEN) LED2 is always on (RED)	Corresponding error
Flashes 3 times and stops for 1 second, then repeats	P1 - High pressure protection
Flashes 5 times and stops for 1 second, then repeats	bH – PED board checking fail
Flashes 8 times and stops for 1 second, then repeats	L0 - Inverter module protection
Flashes 9 times and stops for 1 second, then repeats	L1 - DC bus low voltage protection
Flashes 10 times and stops for 1 second, then repeats	L2 - DC bus high voltage protection
Flashes 12 times and stops for 1 second, then repeats	L4 - MCE error
Flashes 13 times and stops for 1 second, then repeats	L5 - Zero speed protection
Flashes 16 times and stops for 1 second, then repeats	L8 - Compressor frequency variation greater than 15Hz within one second protection
Flashes 17 times and stops for 1 second, then repeats	L9 - Actual compressor frequency differs from target frequency by more than 15Hz protection

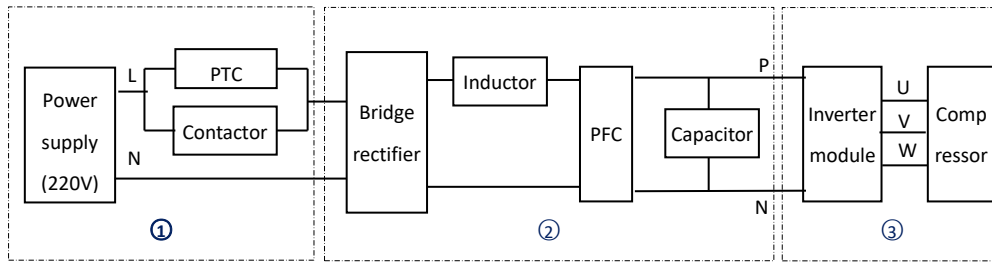
Figure 4-4.1: LED location of inverter module

Inverter Module(4-10KW): LED301/302/303

Inverter Module(12-16KW): LED1/LED2/LED3



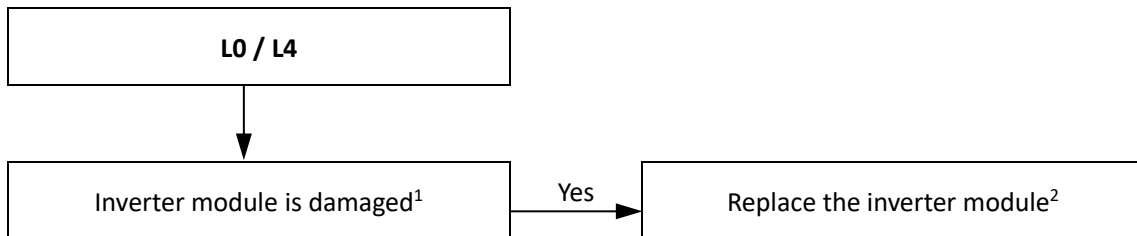
6.20.5 Principle of DC inverter



- ① Contactor is open, the current across the PTC to charge capacitor. After 5 seconds, the contactor closed.
- ② 220-240V AC power supply change to DC power supply after bridge rectifier.
- ③ The capacitor output steady power supply for inverter module P N terminals. In standby the voltage between P and N terminal on inverter module is 1.4 time of AC power supply. When the fan motor is running, the voltage is 377V DC.

6.20.6 L0/L4 troubleshooting

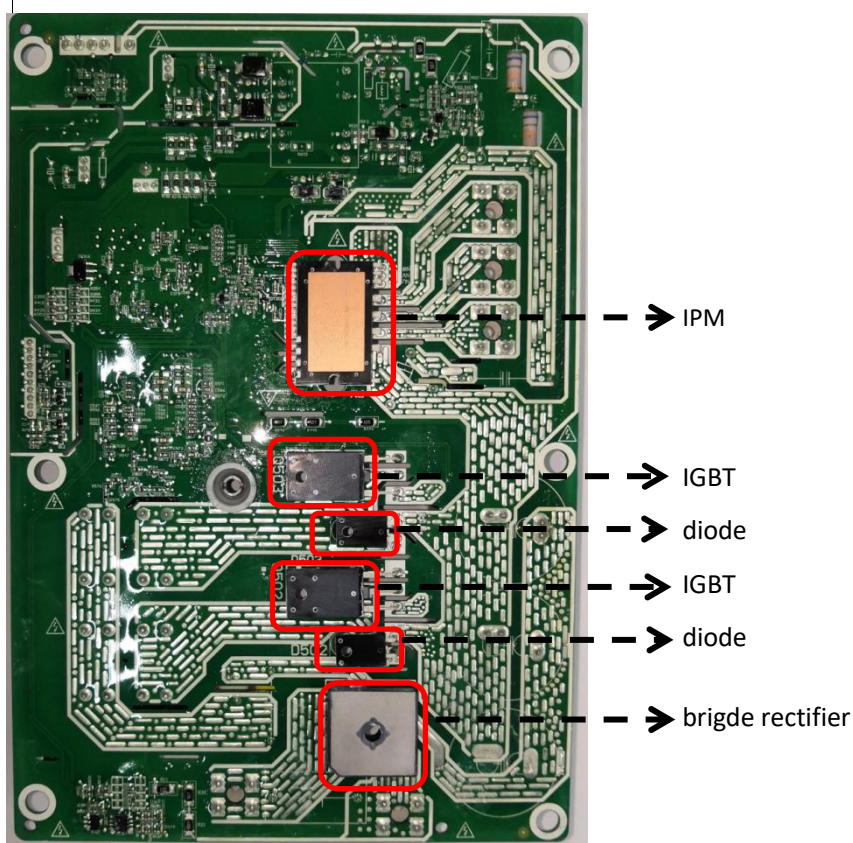
Situation 1: L0 or L4 error appears immediately after the outdoor unit is powered-on



Notes:

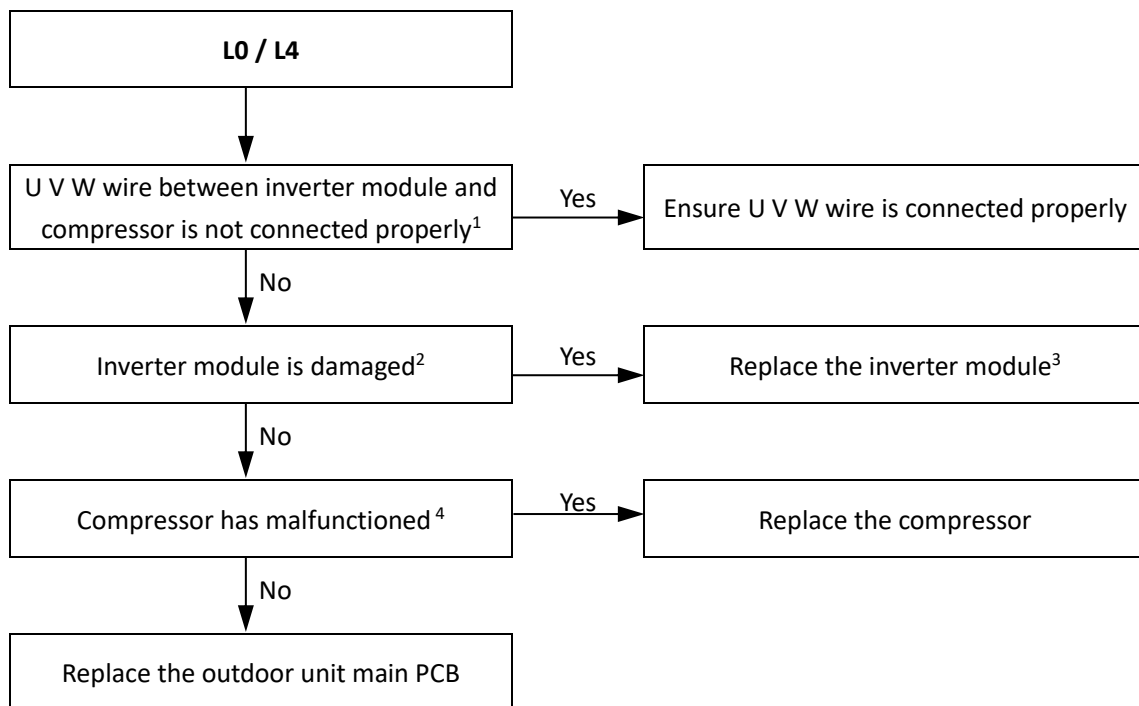
- 1. Measure the resistance between each of U, V and W and each of P and N on the inverter module. All the resistances should be infinite. If any of them are not infinite, the inverter module is damaged and should be replaced. Refer to Figure 4-2.5 to 4-2.7 in Part 4, 2.1 "Main PCBs for Refrigerant System, Inverter Module".
- 2. When replacing an inverter module, a layer of thermally conductive silica gel should be painted on the IPM module, IGBT, diode, bridge rectifier (on the reverse side of the inverter module). Refer to Figure 4-4.2.

Figure 4-4.2: Replacing an inverter module



OPTIMUS PRO Split

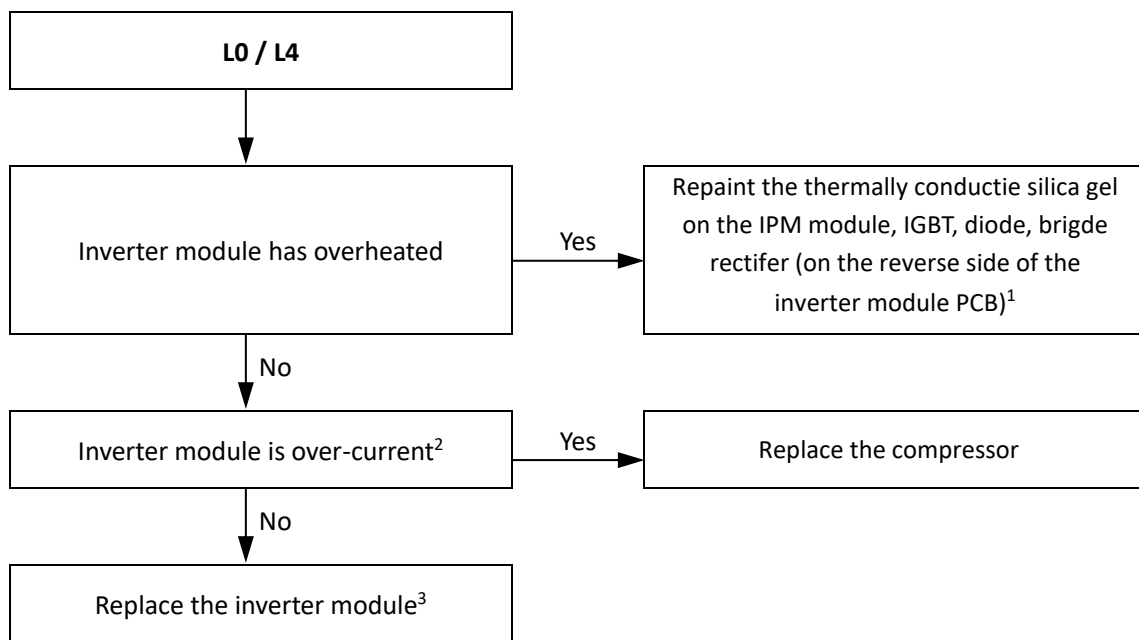
Situation 2: L0 or L4 error appears immediately after the compressor starts up



Notes:

1. Connect the U V W wire from the inverter module to the correct compressor terminals, as indicated by the labels on the compressor.
2. Measure the resistance between each of U, V and W and each of P and N on the inverter module. All the resistances should be infinite. If any of them are not infinite, the inverter module is damaged and should be replaced. Refer to Figure 4-2.5 to 4-2.7 in Part 4, 2.1 "Main PCBs for Refrigerant System, Inverter Module".
3. When replacing an inverter module, a layer of thermally conductive silica gel should be painted on the IPM module, IGBT, diode bridge rectifier (on the reverse side of the inverter module PCB). Refer to Figure 4-4.2.
4. The normal resistances of the inverter compressor are 0.7-1.5Ω among U V W and infinite between each of U V W and ground. If any of the resistances differ from these specifications, the compressor has malfunctioned.

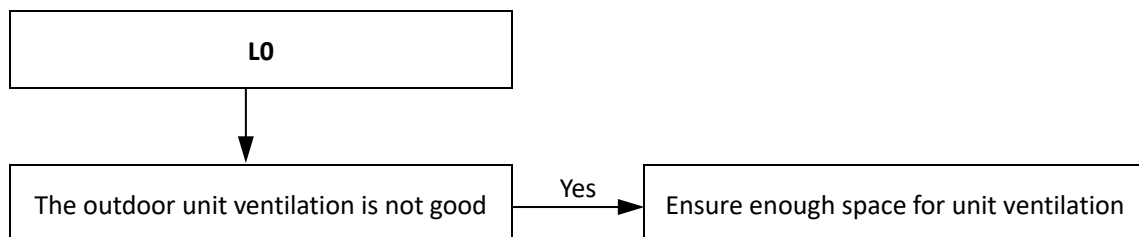
Situation 3: L0 or L4 error appears after the compressor has been running for a period of time and the compressor speed is over 60rps



Notes:

1. Refer to Figure 4-4.2.
2. Use clip-on ammeter to measure the compressor current, if the current is normal indicates the inverter module is failed, if the current is abnormal indicates the compressor is failed.
3. When replacing an inverter module, a layer of thermally conductive silica gel should be painted on the PFC and IPM modules (on the reverse side of the inverter module PCB). Refer to Figure 4-4.2.

Situation 4: L0 error appears occasionally/irregularly



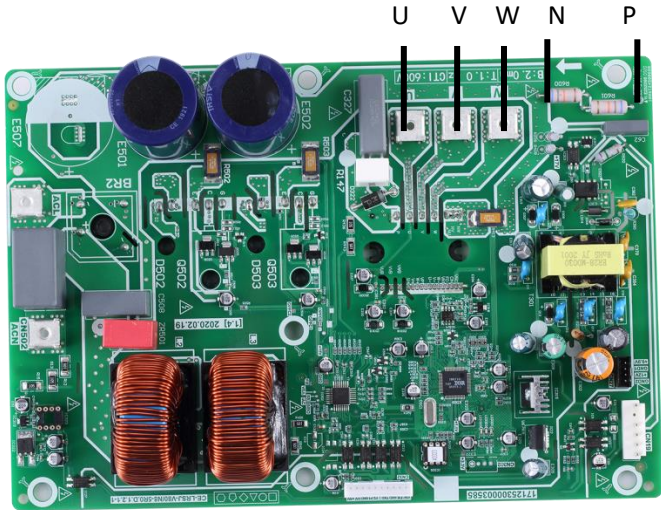
OPTIMUS PRO Split

6.20.7 L1/L2 troubleshooting

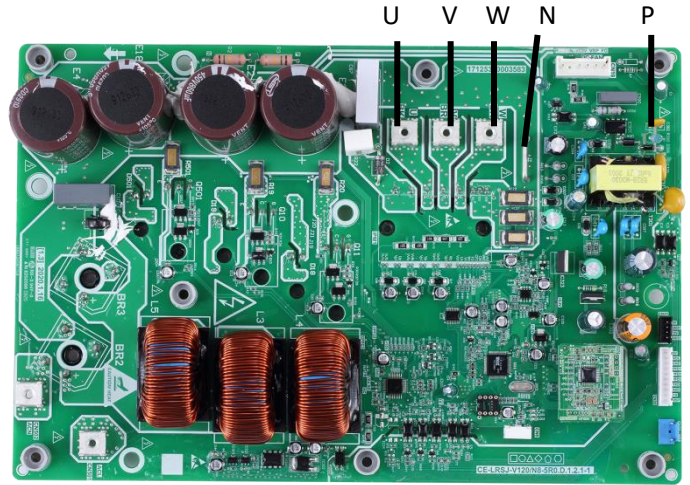
The normal DC voltage between terminals P and N on inverter module is 1.4 time of AC power supply in standby , the DC voltage is 377V when the fan motor is running. If the voltage is lower than 160V, the unit displays L1. If the voltage is higher than 500V, the unit display L2.

Figure 4-4.3: Inverter module terminals

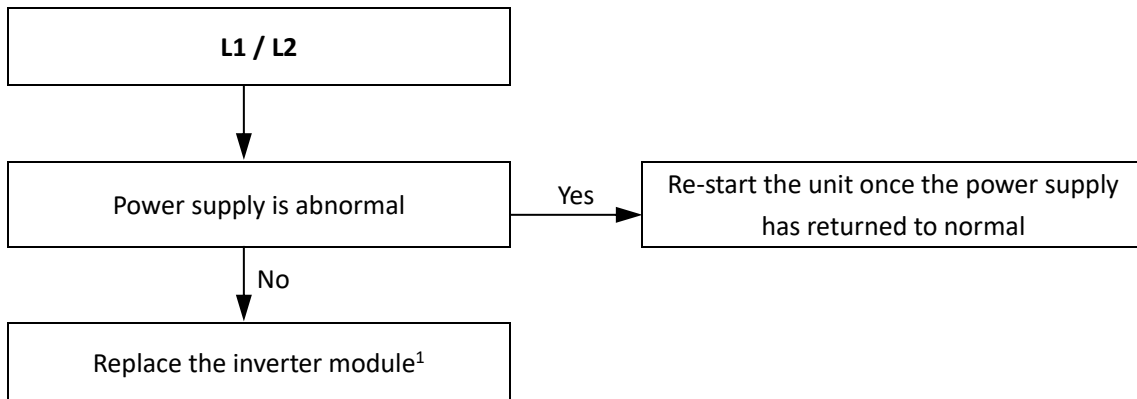
Inverter module terminals (4-10KW)



Inverter module terminals (12-16KW)

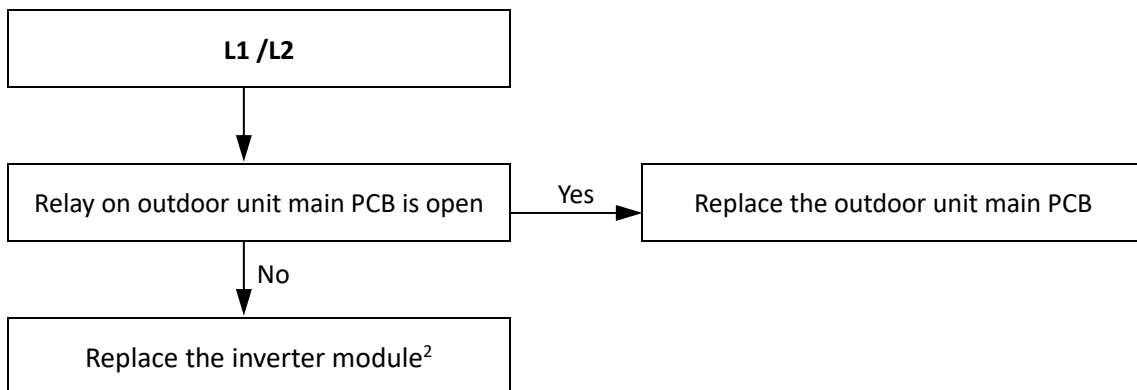


Situation 1: L1 or L2 error appears immediately after the outdoor unit is powered-on



- Notes:
- When replacing an inverter module, a layer of thermally conductive silica gel should be painted on the IPM module, IGBT, diode, bridge rectifier (on the reverse side of the inverter module PCB). Refer to Figure 4-4.2.

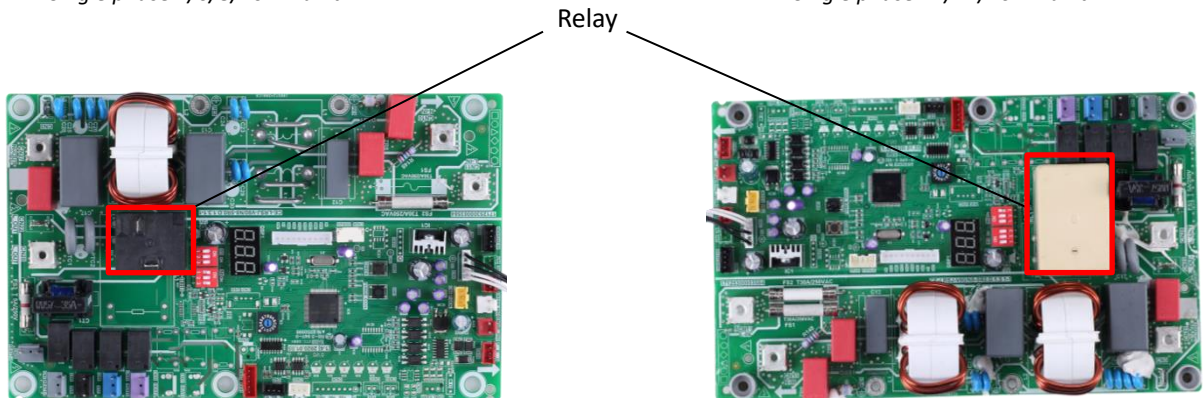
Situation 2: L1 or L2 error appears after the compressor has been running for a period of time and the compressor speed is over 20rps



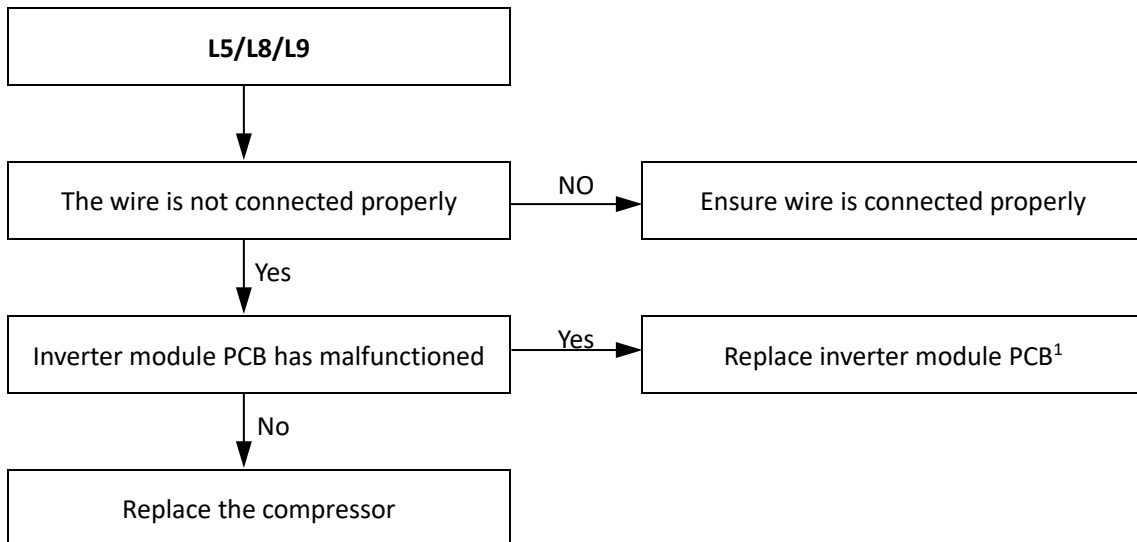
Notes:

1. If the fan motor is running and the DC voltage between terminals P and N on inverter module declined, Relay on the main control board of outdoor unit is open.
2. When replacing an inverter module, a layer of thermally conductive silica gel should be painted on IPM module (on the reverse side of the inverter module PCB). Refer to Figure 4-4.2.

Figure 4-4.4: Relay location of main PCB for refrigerant system
Single phase 4/6/8/10kW unit



6.20.8 L5/L8/L9 troubleshooting

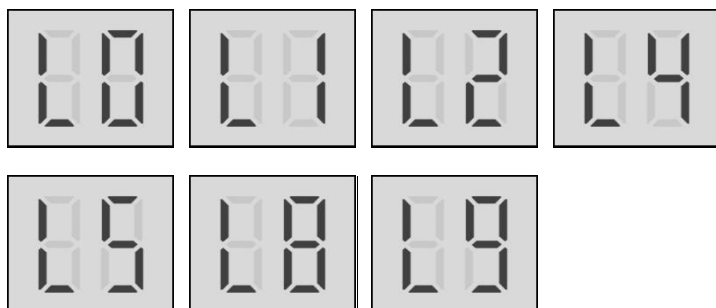


1. When replacing an inverter module, a layer of thermally conductive silica gel should be painted on IPM module (on the reverse side of the inverter module PCB). Refer to Figure 4-4.2.

OPTIMUS PRO Split

6.21 Inverter module Troubleshooting for three-phase models

6.21.1 Digital display output



6.21.2 Description

- Inverter module protection or high pressure protection.
- OPTIMUS PRO Split stops running.
- Specific error code L0, L1, L2, L4, L5, L8, L9 is displayed on the user interface and the refrigerant system main PCB.

6.21.3 Possible causes

- Inverter module protection.
- DC bus low or high voltage protection.
- MCE error(DC bus low or high voltage protection or software over current protection)
- Zero speed protection.
- Excessive compressor frequency variation.
- Actual compressor frequency differs from target frequency.
- High pressure protection.
- Contactor stuck or 908 self checking fail.

6.21.4 Specific error codes for inverter module protection

Table 4-4.4: Specific error codes

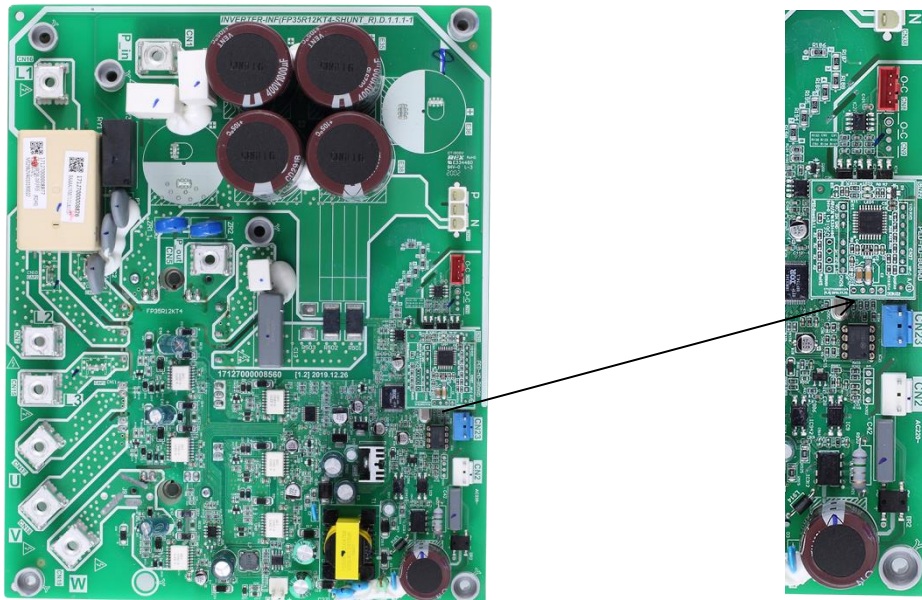
Specific error code	Content
L0	Inverter module protection
L1	DC bus low voltage protection
L2	DC bus high voltage protection
L4	MCE error(DC bus low or high voltage protection or software over current protection)
L5	Zero speed protection
L8	Compressor frequency variation greater than 15Hz within one second protection
L9	Actual compressor frequency differs from target frequency by more than 15Hz protection

The specific error codes can also be obtained from the LED indicators LED1/LED2 on the inverter module.

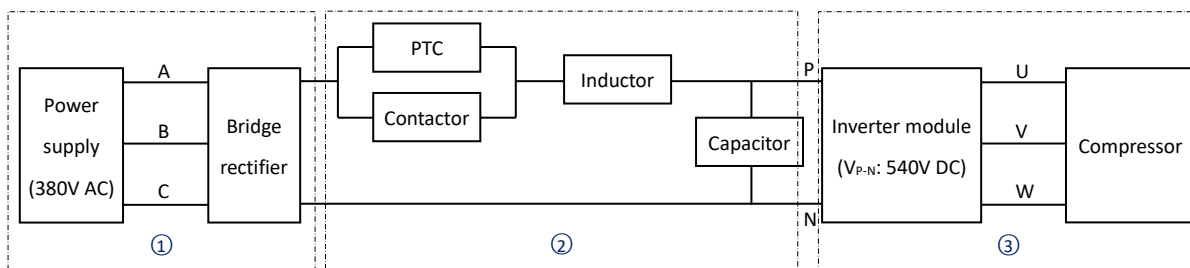
Table 4-4.5: Errors indicated on LED for three-phase 12~16kW unit

LED1/2 flashing pattern	Corresponding error
Flashes 8 times and stops for 1 second, then repeats	L0 - Inverter module protection
Flashes 9 times and stops for 1 second, then repeats	L1 - DC bus low voltage protection
Flashes 10 times and stops for 1 second, then repeats	L2 - DC bus high voltage protection
Flashes 12 times and stops for 1 second, then repeats	L4 - MCE error(DC bus low or high voltage protection or software over current protection)
Flashes 13 times and stops for 1 second, then repeats	L5 - Zero speed protection
Flashes 17 times and stops for 1 second, then repeats	L8 - Compressor frequency variation greater than 15Hz within one second protection L9 - Actual compressor frequency differs from target frequency by more than 15Hz protection
Flashes 3 times and stops for 1 second, then repeats	bH - Contactor stuck or 908 self checking fail
Flashes 5 times and stops for 1 second, then repeats	P1 - High pressure protection

Figure 4-4.5: LED location of inverter module for three-phase 12~16kW unit



6.21.5 Principle of DC inverter

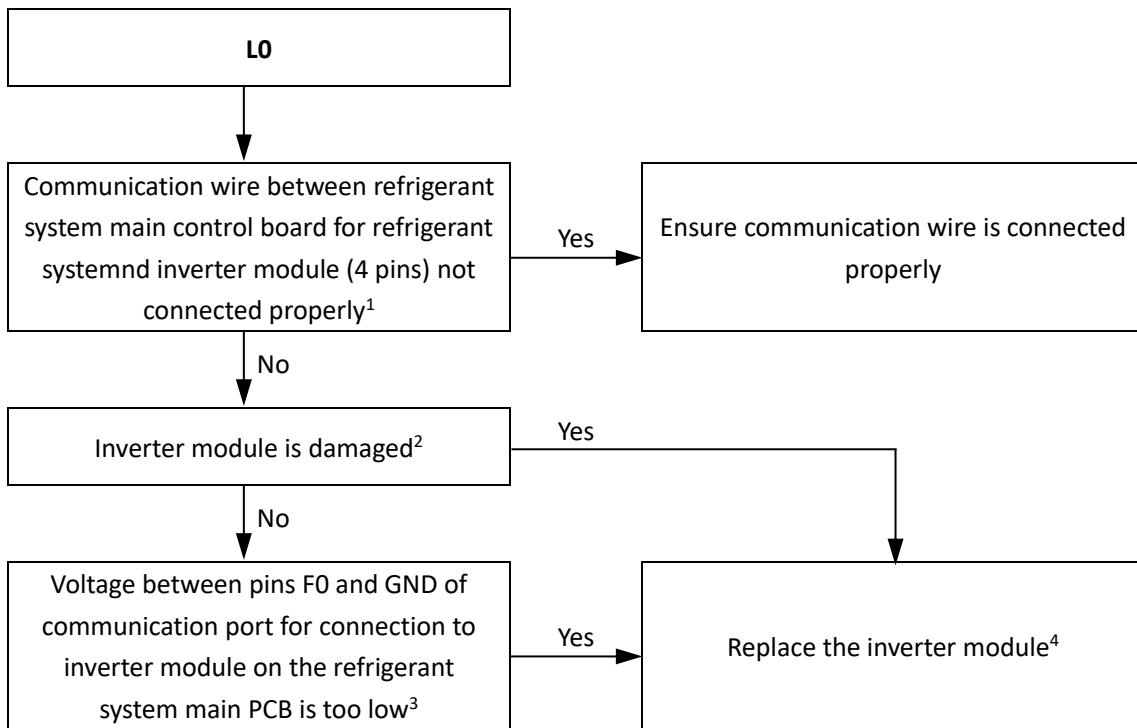


- ① 380-415V AC power supply change to DC power supply after bridge rectifier.
- ② Contactor is open the current across the PTC to charge capacitor, after 5 seconds the contactor closed.
- ③ The capacitor output steady 540V DC power supply for inverter module P N terminals.

OPTIMUS PRO Split

6.21.6 L0 troubleshooting

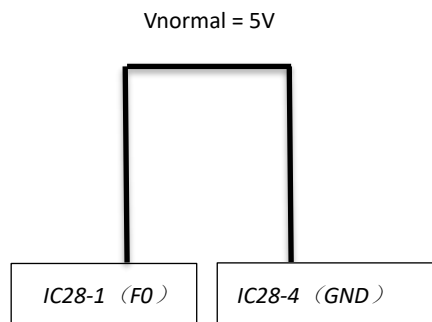
Situation 1: L0 error appears immediately after the outdoor unit is powered-on



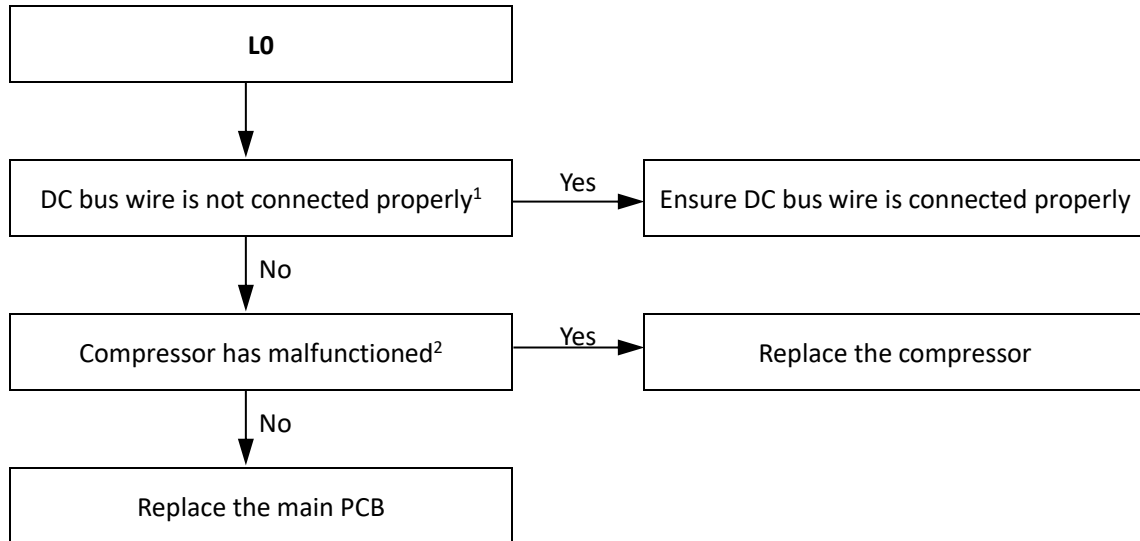
Notes:

1. For HOP12(14,16)WODU3, the communication port between refrigerant system main control board for refrigerant system inverter module is port CN36 on refrigerant system main control board for refrigerant system port CN8 on inverter module.
2. Measure the resistance between each of U, V and W and each of P and N on the inverter module. All the resistances should be infinite. If any of them are not infinite, the inverter module is damaged and should be replaced.
3. The normal voltage between F0 and GND is 5V. Refer to Figure 4-4.6.
4. When replacing an inverter module, a layer of thermally conductive silica gel should be painted on the IPM module (on the reverse side of the inverter module PCB). Refer to Figure 4-4.2.

Figure 4-4.6: F0 and GND voltage on IC28-1 (F0), IC28-4 (GND)



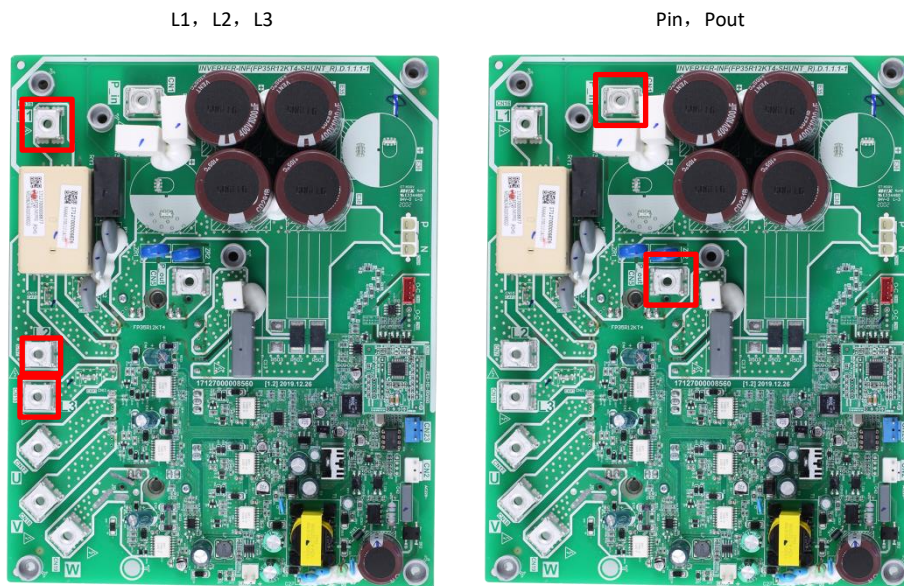
Situation 2: L0 error appears immediately after the compressor starts up



Notes:

1. The DC bus wire should run from the N terminal on the inverter module, through the current sensor (in the direction indicated by the arrow on the current sensor), and end at the N terminal of capacitor. Refer to Figure 4-4.7.

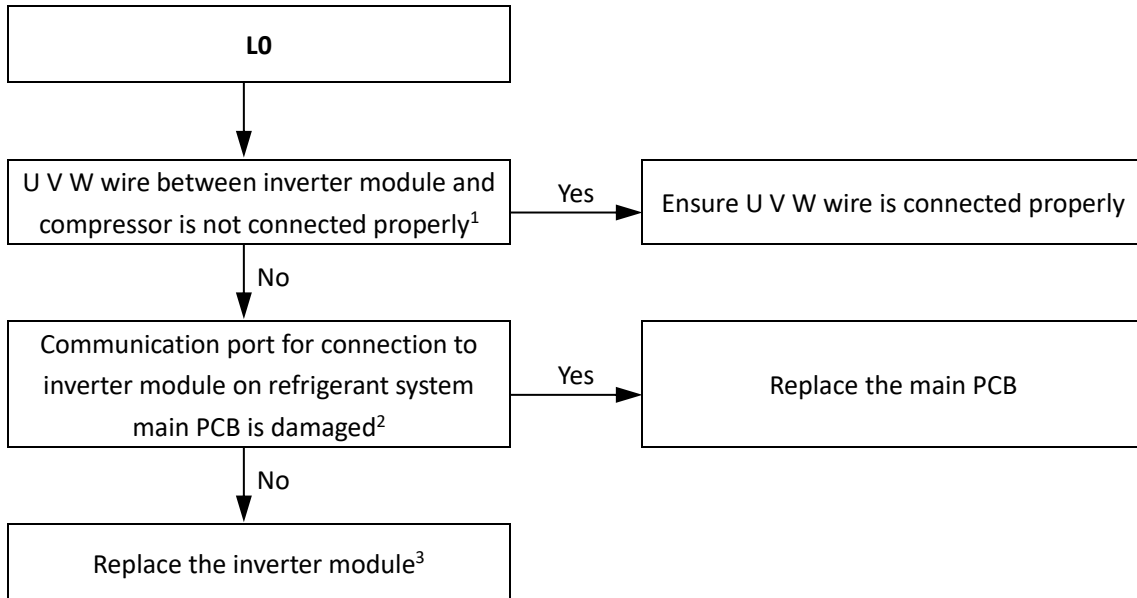
Figure 4-4.7: DC bus wire connection (L1L2L3, PIN- POUT)



2. The normal resistances of the inverter compressor are 0.7-1.5Ω among U V W and infinite between each of U V W and ground. If any of the resistances differ from these specifications, the compressor has malfunctioned.

OPTIMUS PRO Split

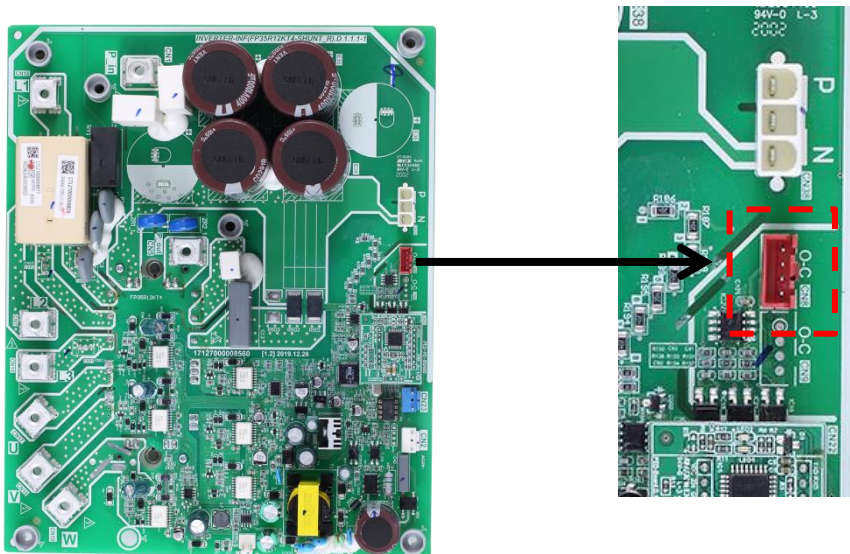
Situation 3: L0 error appears within 2 seconds of compressor start-up



Notes:

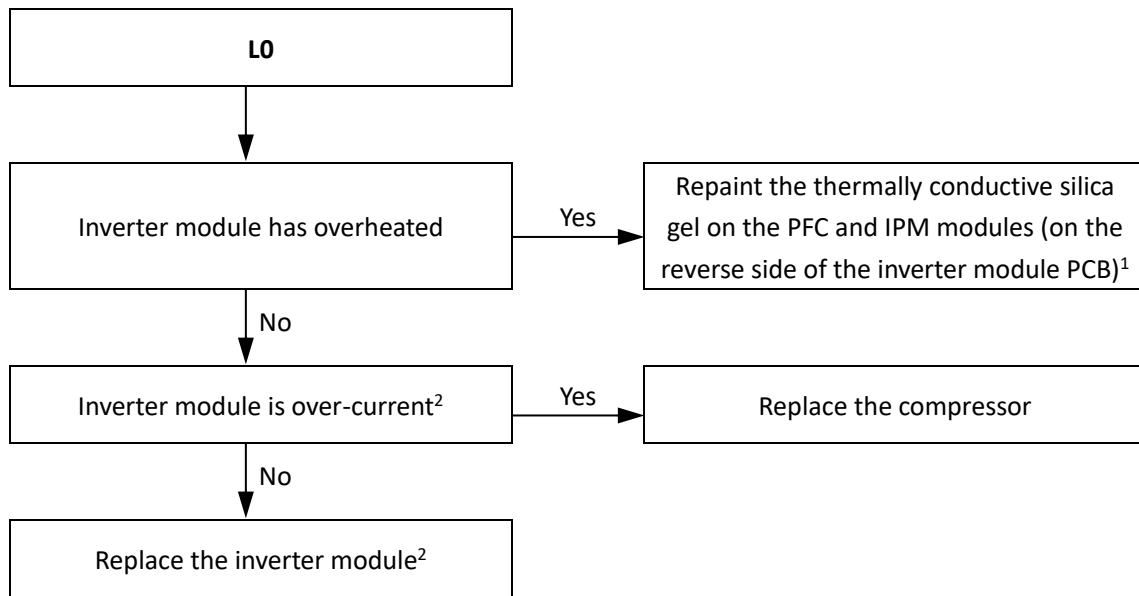
1. Connect the U V W wire from the inverter module to the correct compressor terminals, as indicated by the labels on the compressor.
2. Measure the voltage between each of W-, W+, V-, V+, U-, U+ and GND when the unit is in standby. The normal voltage should be 2.5V-4V and the six voltages should be same, otherwise the communication terminal has failed. Refer to Figure4-4.8.

Figure 4-4.8: Connection port for inverter module



3. When replacing an inverter module, a layer of thermally conductive silica gel should be painted on the IPM module (on the reverse side of the inverter module PCB). Refer to Figure 4-4.2.

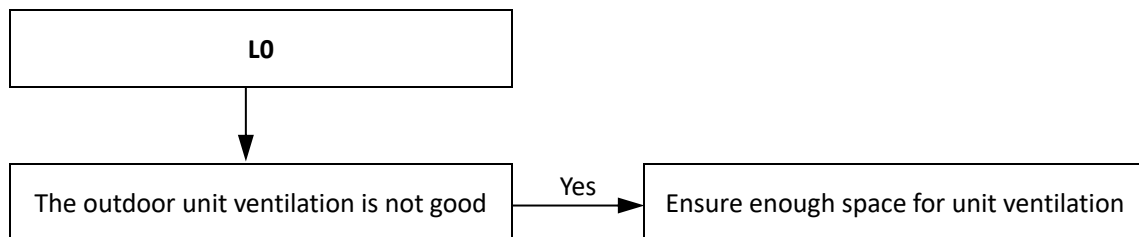
Condition 4: L0 error appears after the compressor has been running for a period of time and the compressor speed is over 60rps



Notes:

1. When replacing an inverter module, a layer of thermally conductive silica gel should be painted on the IPM module (on the reverse side of the inverter module PCB).
2. Use clip-on ammeter to measure the compressor current, if the current is normal indicates the inverter module is failed, if the current is abnormal indicates the compressor has failed.

Situation 5: L0 error appears occasionally/irregularly

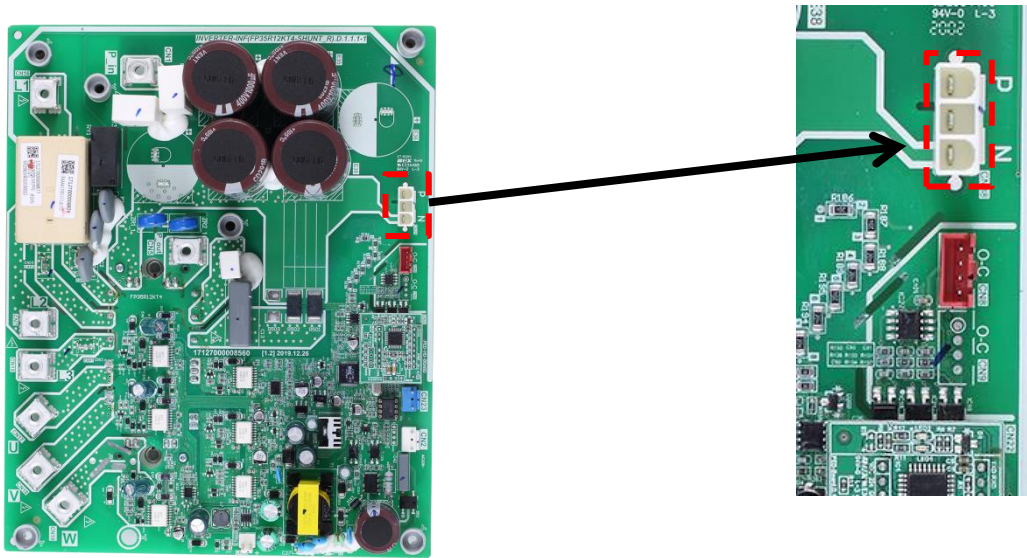


OPTIMUS PRO Split

6.21.7 L1/L2 troubleshooting

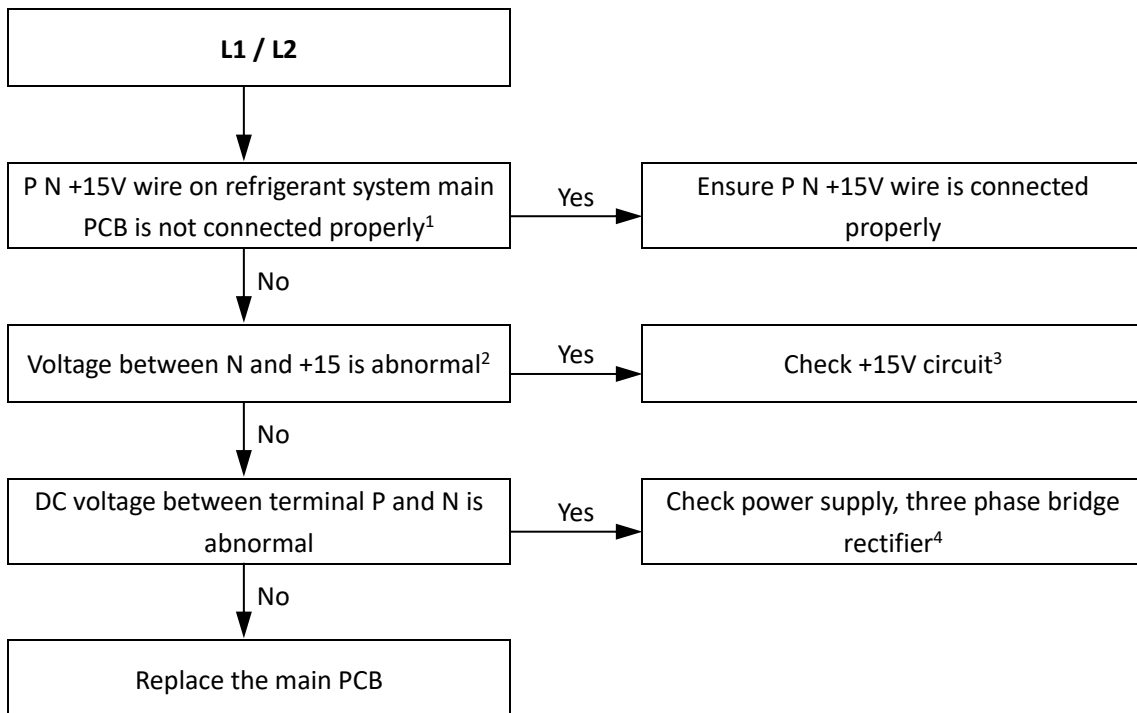
The normal DC voltage between terminals P and N on inverter module is 540V. If the voltage is lower than 300V, the unit displays an L1 error; if the voltage is higher than 830V, the unit displays an L2 error. Refer to Figure4-4.9.

Figure 4-4.9: P, N terminals voltage



$V_{\text{normal}} = 540\text{V DC}$

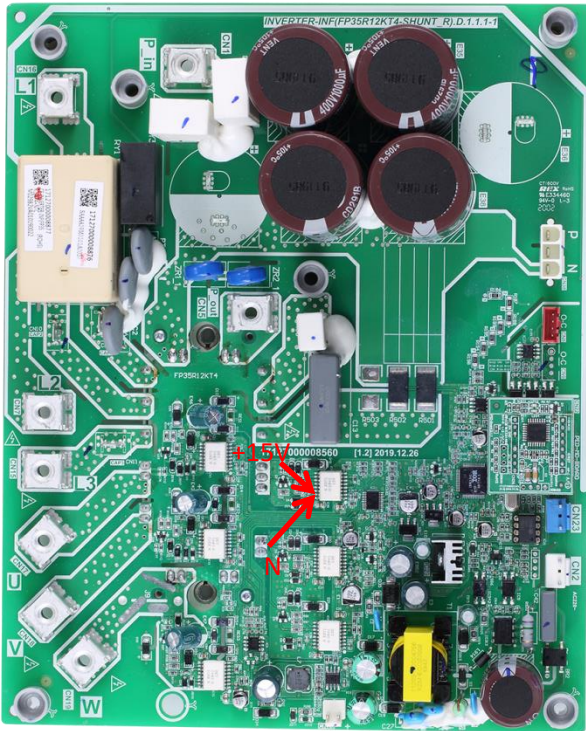
Situation 1: L1 or L2 error appears immediately after the outdoor unit is powered-on



Notes:

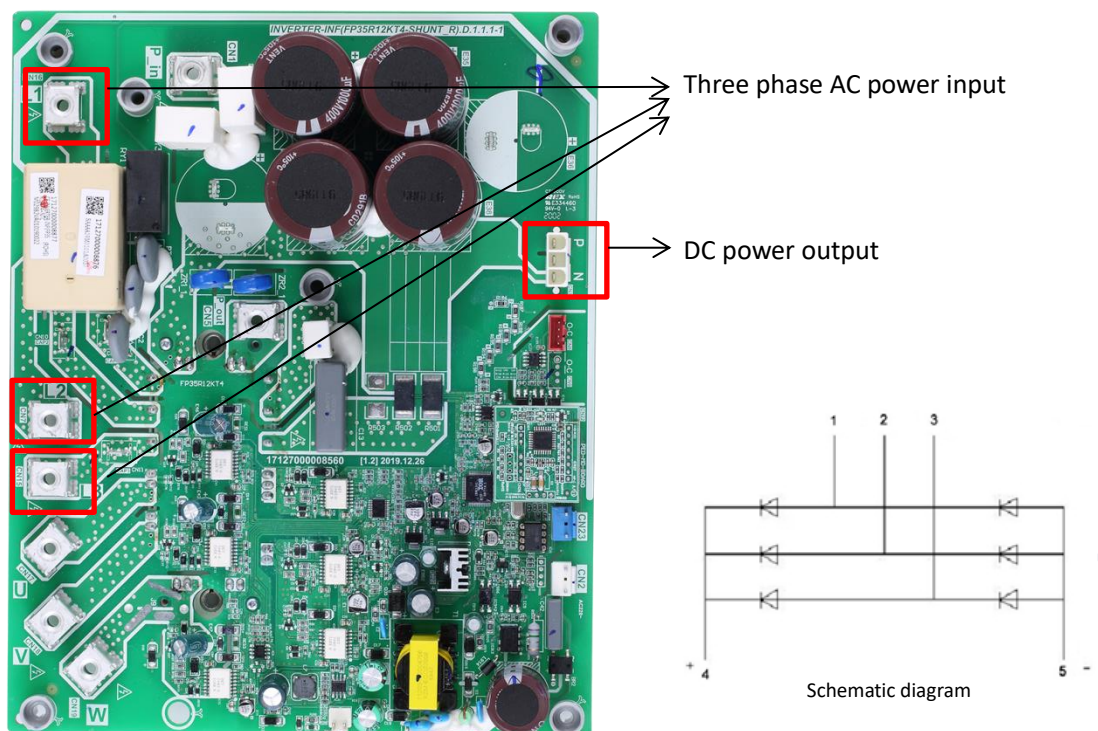
1. P N +15V terminal on refrigerant system main PCB. Refer to Figure4-4.9.
2. Voltage between N and +15. Refer to Figure4-4.10

Figure 4-4.10: P N +15V terminal+15V (IC4/5/6PIN12); N- (IC/4/5、6) PIN13



3. Check the +15V circuit according to corresponding wiring diagram. If IC4/5/6PIN12 on inverter module output voltage is not +15V means the inverter module is failed. If voltage output of inverter module is +15V means main PCB is failed.
4. Check the bridge rectifier using one of the following two methods (refer to Figure 4-4.11):
 - Method 1: measure the resistance between any two of the 5 bridge rectifier terminals. If any of the resistances is close to zero, the bridge rectifier has failed.
 - Method 2: dial a multimeter to the diode setting:
 - Put the red probe on the DC power output negative terminal (terminal 5) and put the black probe onto each of the AC power input terminals (terminals 1, 2 and 3) in turn. The voltage between terminal 5 and each of terminals 1, 2 and 3 should be around 0.378V. If the voltage is 0, the bridge rectifier has failed.
 - Put the red probe on the DC power output positive terminal (terminal 4), then put black probe onto each of the AC power input terminals (terminals 1, 2 and 3) in turn. The voltage between terminal 4 and each of terminals 1, 2 and 3 should be infinite. If the voltage is 0, the bridge rectifier has failed.

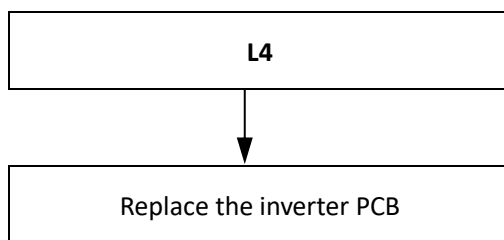
Figure 4-4.11: Bridge rectifier



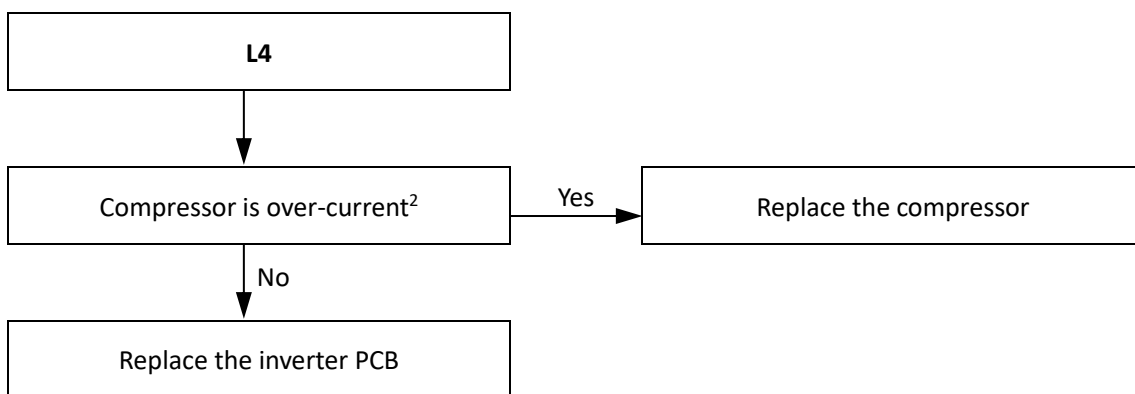
OPTIMUS PRO Split

6.21.8 L4 troubleshooting(the same as L1/L2)

Situation 1: L4 error appears immediately after the outdoor unit is powered-on



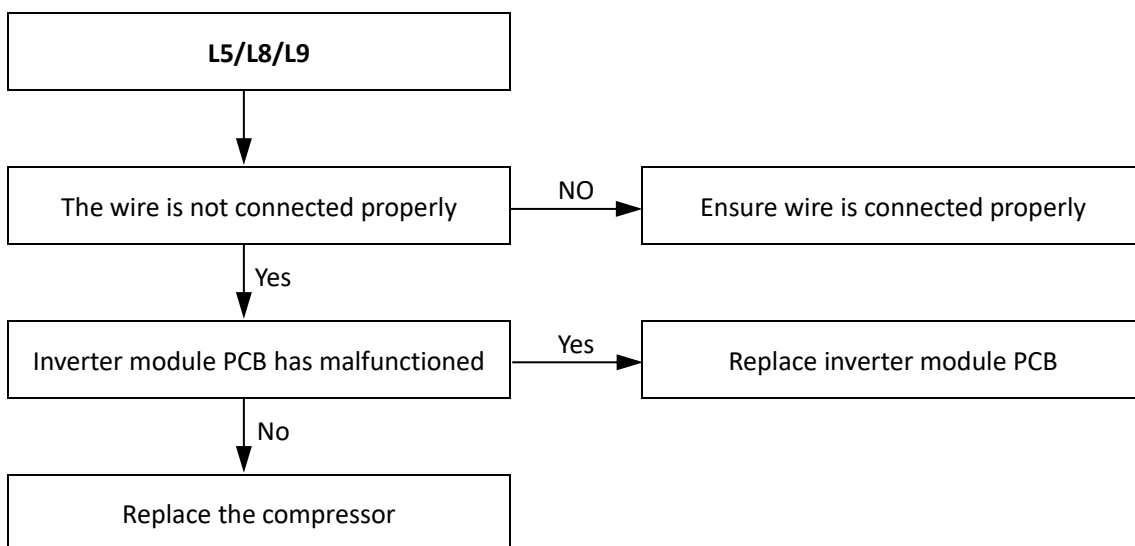
Condition 2: L4 error appears after the compressor has been running for a period of time and the compressor speed is over 60rps



Notes:

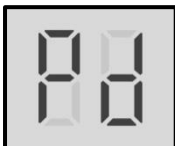
1. Re-start the unit, use clip-on ammeter to measure the compressor current, if the current is normal indicates the compressor is failed, if the current is abnormal indicates the inverter PCB is failed..

6.21.9 L5/L8/L9 troubleshooting



6.22 Pd Troubleshooting

6.22.1 Digital display output



6.22.2 Description

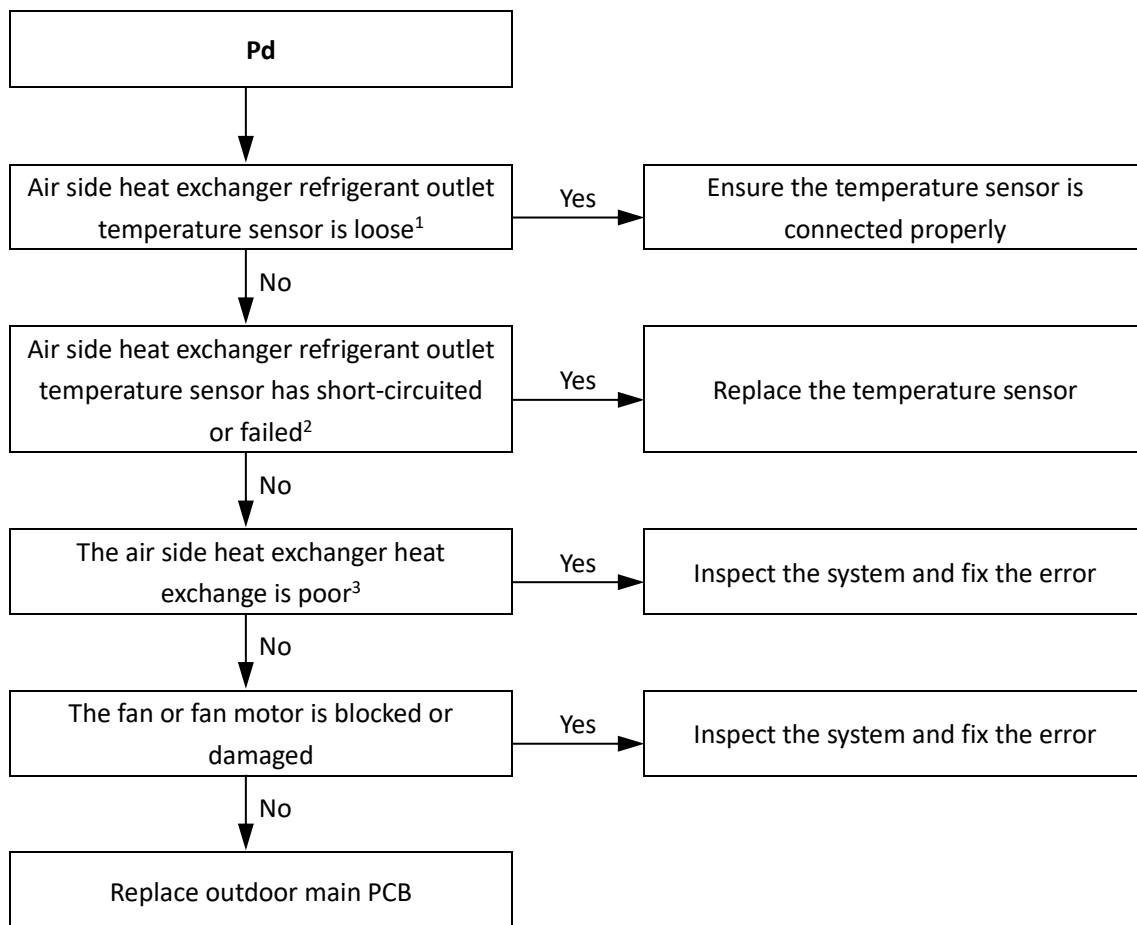
- High temperature protection of air side heat exchanger refrigerant outlet in cooling mode. When the air side heat exchanger refrigerant outlet temperature is higher than 61°C for more than 3 seconds, the system displays Pd protection and OPTIMUS PRO Split stops running. When the air side heat exchanger refrigerant outlet temperature returns drops below 55°C, Pd is removed and normal operation resumes.
- OPTIMUS PRO Split stops running.
- Error code is displayed on outdoor unit main PCB and user interface.

6.22.3 Possible causes

- Temperature sensor not connected properly or has malfunctioned.
- Poor condenser heat exchange.
- Fan motor damaged.
- Hydronic box main PCB damaged.

OPTIMUS PRO Split

6.22.4 Procedure

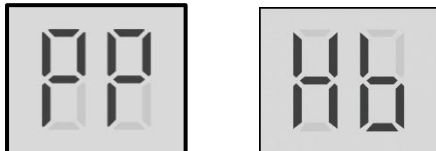


Notes:

1. Air side heat exchanger refrigerant outlet temperature sensor and outdoor ambient temperature sensor connection port are CN9 on the HOP4(6,8,10)WODU outdoor unit refrigerant system main PCB (labeled 12 in Figure 4-2.2 in Part4, 2.3 "Main PCB for Refrigerant System, Inverter Module"). port CN9 on the HOP12(14,16)WODU outdoor unit refrigerant system main PCB (labeled 12 in Figure 4-2.3 in Part 4, 2. 3 "Main PCB for Refrigerant System, Inverter Module"), port CN9 on the HOP12(14,16)WODU3 outdoor unit refrigerant system main PCB (labeled 17 in Figure 4-2.4 in Part 4, 2. 3 "Main PCB for Refrigerant System, Inverter Module")
2. Measure sensor resistance. If the resistance is too low, the sensor has short-circuited. If the resistance is not consistent with the sensor's resistance characteristics table, the sensor has failed. Refer to Part 2, 1.1 "Outdoor Unit Layout" and to Table 4-5.1 in Part 4, 5.1 "Temperature Sensor Resistance Characteristics".
3. Check air side heat exchanger, fan and air outlets for dirt/blockages.
4. High pressure switch connection is port CN13 on the

6.23 PP Troubleshooting

6.23.1 Digital display output



6.23.2 Description

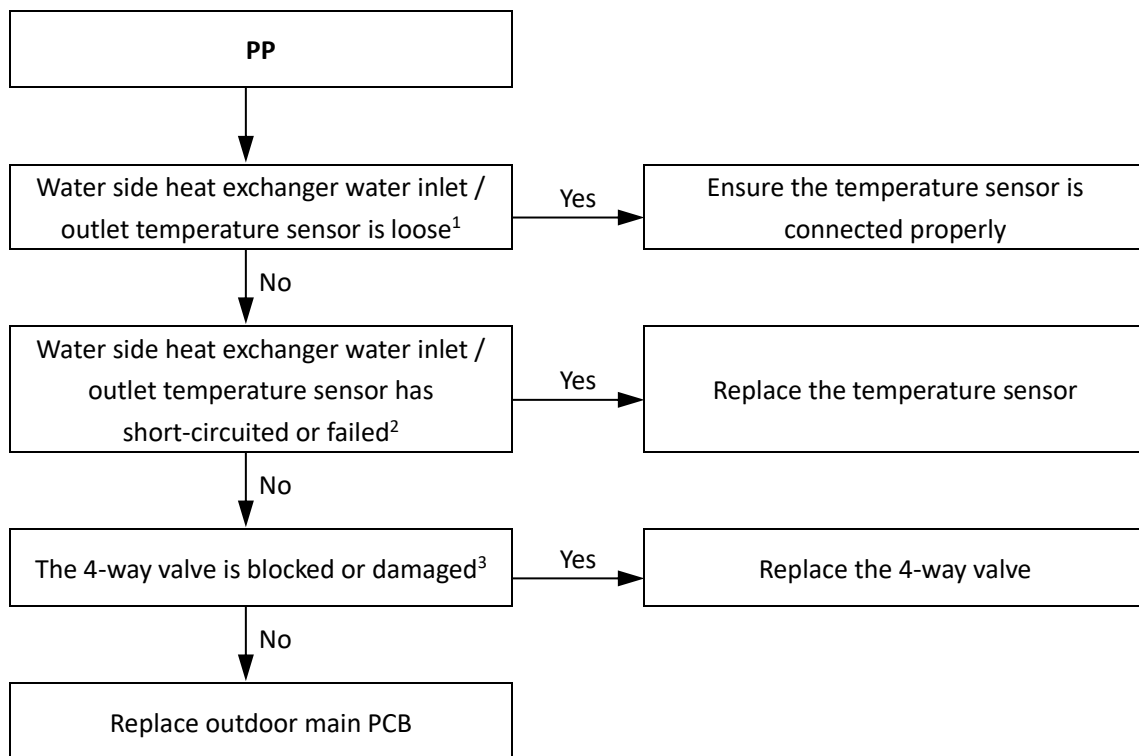
- Water side heat exchanger inlet temperature is higher than outlet temperature in heating mode.
- OPTIMUS PRO Split stops running.
- Error code is displayed on hydronic box main PCB and user interface. Hb indicates PP has displayed 3 times.

6.23.3 Possible causes

- Temperature sensor not connected properly or has malfunctioned.
- 4-way valve is blocked or damaged.
- Hydronic box main PCB damaged.

OPTIMUS PRO Split

6.23.4 Procedure

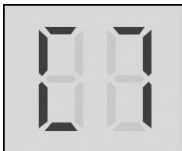


Notes:

1. Water side heat exchanger water inlet temperature sensor and water side heat exchanger water outlet temperature sensor connections are port CN6 on the hydronic box main PCB (labeled 10 in Figure 4-2.1 in Part4, 2.2 "Main PCB for Hydronic System").
2. Measure sensor resistance. If the resistance is too low, the sensor has short-circuited. If the resistance is not consistent with the sensor's resistance characteristics table, the sensor has failed. Refer to Part 2, 1.2 "Hydronic Box Layout" and to Table 4-5.3 in Part 4, 5.1 "Temperature Sensor Resistance Characteristics".
3. Restart the unit in cooling mode to change the refrigerant flow direction. If the unit does not operate normally, the 4-way valve is blocked or damaged.

6.24 C7 Troubleshooting

6.24.1 Digital display output

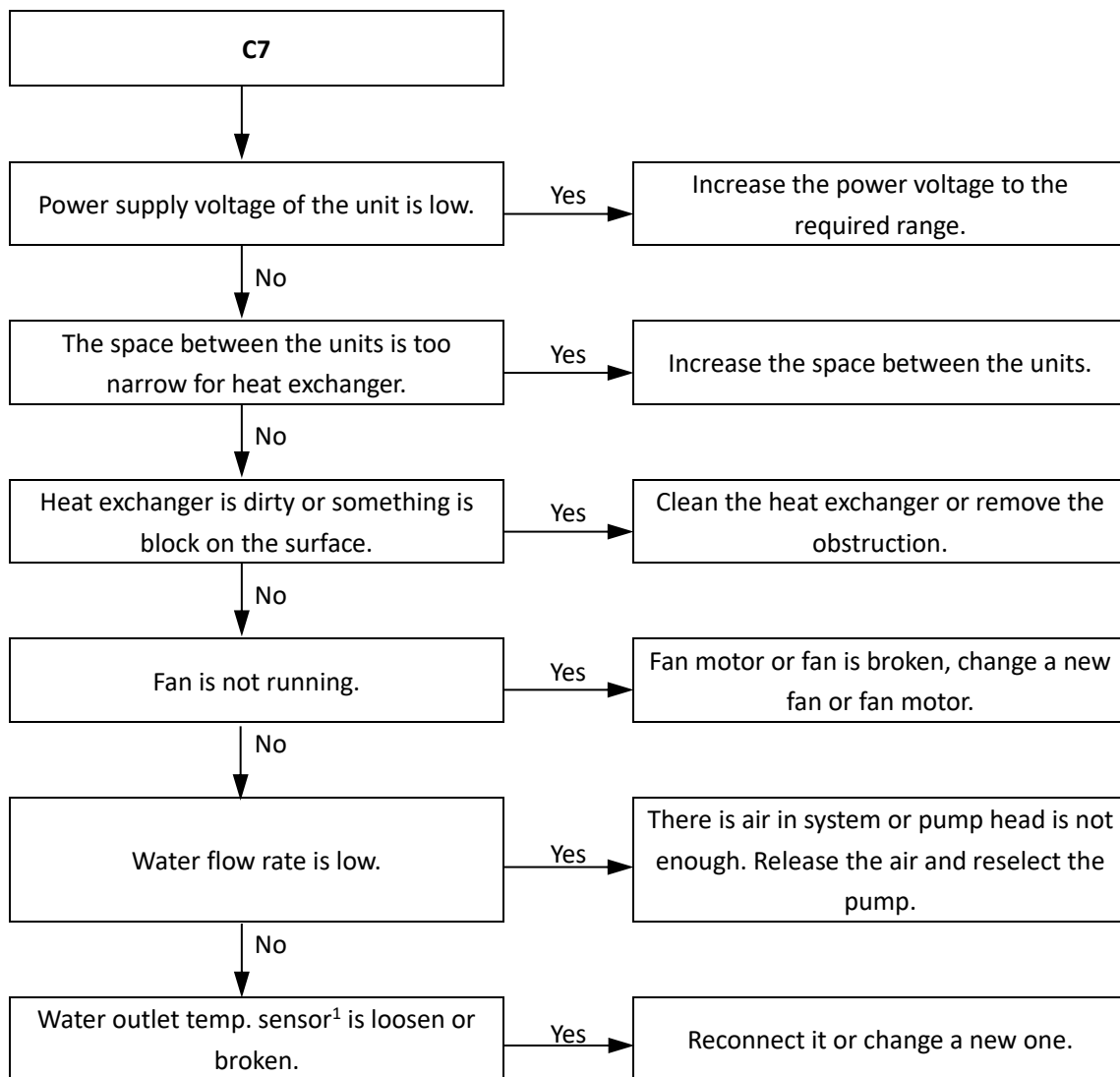


6.24.2 Description

- Transducer module temperature too high protection
- OPTIMUS PRO Split stops running.
- Error code is displayed on hydronic box main PCB and user interface.

6.24.3 Possible causes

- Power supply voltage of the unit is low.
- The space between the units is too narrow for heat exchanger.
- Heat exchanger is dirty or something is block on the surface.
- Fan is not running.
- Water flow rate is low.
- Water outlet temp. sensor is loosen or broken.

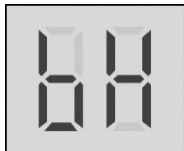


Notes:

1. Water side heat exchanger water inlet temperature sensor and water side heat exchanger water outlet temperature sensor connections are port CN6 on the hydronic box main PCB (labeled 10 in Figure 4-2.1 in Part4, 2.2 "Main PCB for Hydronic System").
2. Measure sensor resistance. If the resistance is too low, the sensor has short-circuited. If the resistance is not consistent with the sensor's resistance characteristics table, the sensor has failed. Refer to Part 2, 1.2 "Hydronic Box Layout" and to Table 4-5.3 in Part 4, 5.1 "Temperature Sensor Resistance Characteristics".

6.25 bH Troubleshooting

6.25.1 Digital display output



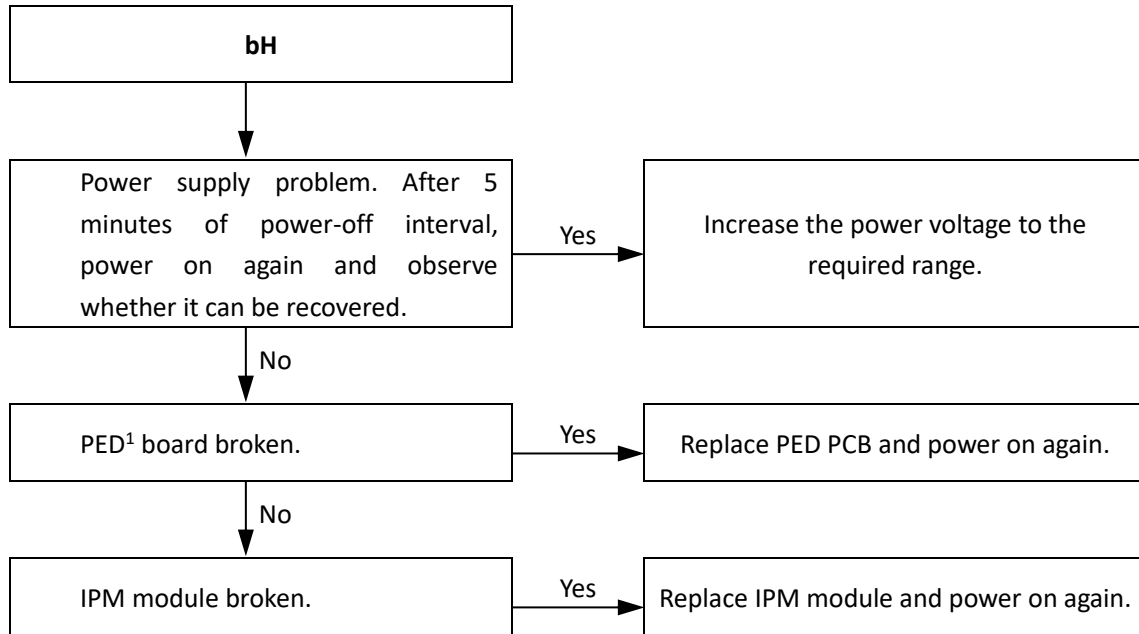
6.25.2 Description

- PED PCB failure
- OPTIMUS PRO Split stops running.
- Error code is displayed on hydronic box main PCB and user interface.

6.25.3 Possible causes

- Power supply problem.
- PED board broken.
- IPM module broken.

6.25.4 Procedure



Notes:

1. PED is port CN22 on the hydronic box main PCB (labeled 11 in Figure 4-2.7: HOP12(14,16)WODU3 outdoor unit inverter module).

6.26 Pb Troubleshooting

6.26.1 Digital display output



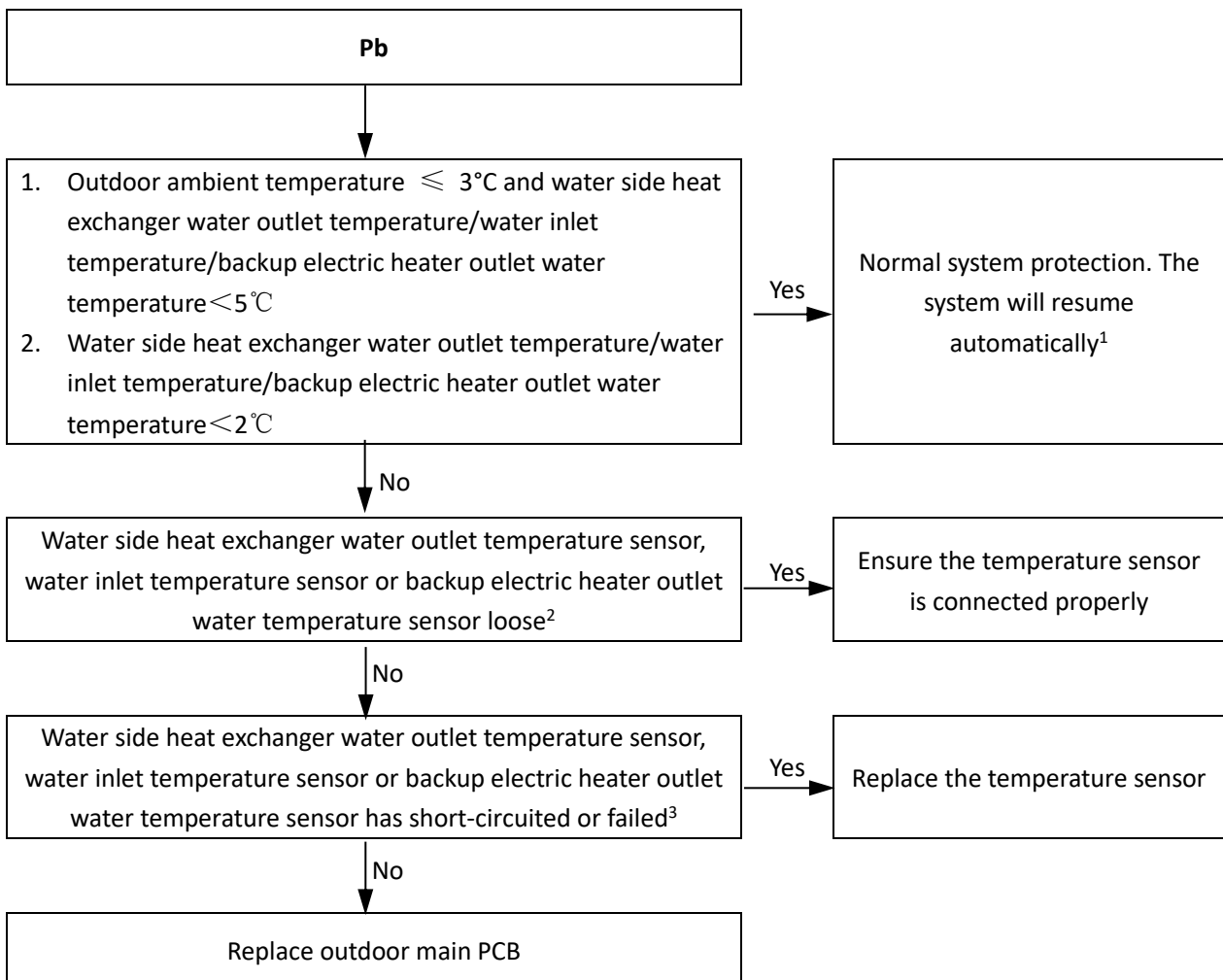
6.26.2 Description

- Water side heat exchanger anti-freeze protection.
- OPTIMUS PRO Split stops running.
- Error code is displayed on hydronic box main PCB and **ANTI.FREEZE** icon is displayed on user interface.

6.26.3 Possible causes

- Normal system protection.
- Temperature sensor not connected properly or has malfunctioned.
- Hydronic box main PCB damaged.

6.26.4 Procedure



Notes:

- Refer to Part 3, 5.7 "Water Side Heat Exchanger Anti-freeze Protection Control".
- Final outlet water temperature sensor, water side heat exchanger water inlet temperature sensor and water side heat exchanger water outlet temperature sensor connections are port CN6 on the hydronic box main PCB (labeled 10 in Figure 4-2.1 in Part4, 2.2 "Main PCB for Hydronic System").
- Measure sensor resistance. If the resistance is too low, the sensor has short-circuited. If the resistance is not consistent with the sensor's resistance characteristics table, the sensor has failed. Refer to Part 2, 1.2 "Hydronic Box Layout" and to Table 4-5.3 in Part 4, 5.1 "Temperature Sensor Resistance Characteristics".

OPTIMUS PRO Split

7 USB function guidelines

7.1 Parameters setting transfer between wired controllers

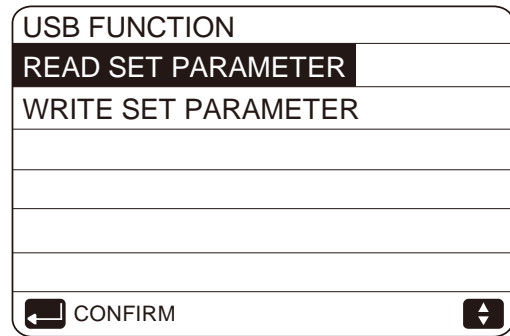
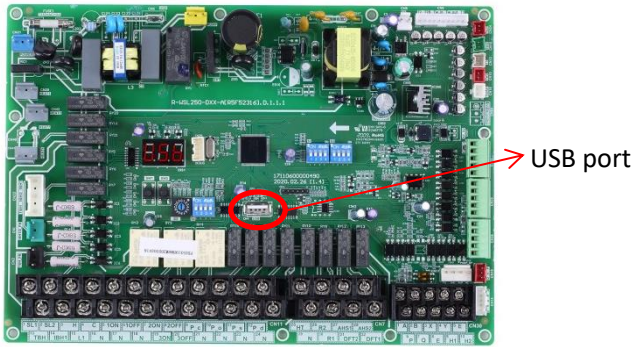
Installer can quickly copy the wired controller parameter settings from unit A to unit B via USB disk, which save the time of on-site installation. Steps are as follows:

Step 1:

Plug U disk into the port of hydronic PCB of A unit.

“USB” appears on digital display

Wired controller interface automatically changes



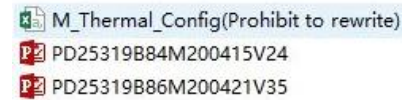
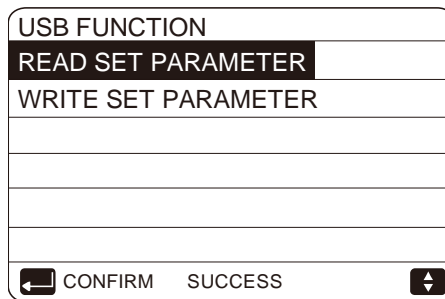
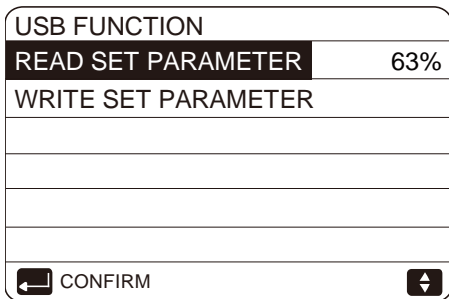
Step 2:

Select “READ SET PARAMETER” and press “OK” button then rate of progress will appear. When the process is finished, “SUCCESS” appears below and an EXCEL file which can not be seen in the wired controller interface but users can find it on computer will be generated inside the USB disk.

Select “READ SET PARAMETER”

Finished

EXCEL generated



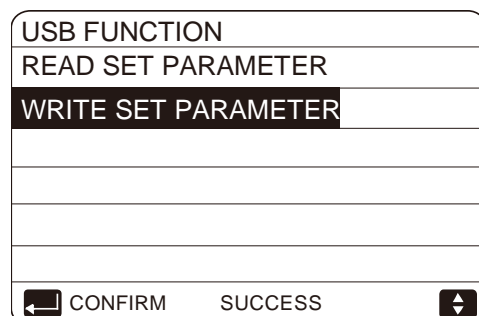
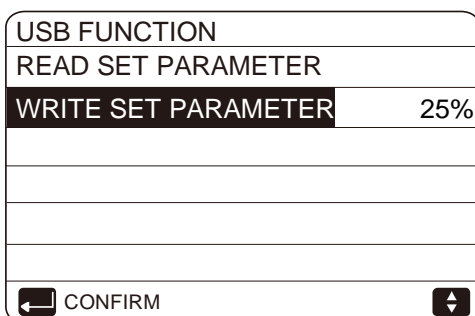
After that, if parameter correction is needed, please connect the USB with computer and open the EXCEL file to change parameters and then save it. Please do not change the file name or format. Parameters are not allowed for non-professionals to change and NØRDIS recommends to use the wired controller to change the parameters.

Step 3:

Plug USB disk into the port of hydronic PCB of B unit and select “WRITE SET PARAMETER” then rate of progress will appear. When the process is finished, “SUCCESS” appears below.

Select “WRITE SET PARAMETER”

Finished



OPTIMUS PRO Split

8 Appendix to Part 4

8.1 Temperature Sensor Resistance Characteristics

Table 4-5.1: Outdoor ambient temperature sensor, water side heat exchanger refrigerant inlet / outlet (liquid / gas pipe) temperature sensor, air side heat exchanger refrigerant out temperature sensor and suction pipe temperature sensor resistance characteristics

Temperature (°C)	Resistance (kΩ)	Temperature (°C)	Resistance (kΩ)	Temperature (°C)	Resistance (kΩ)	Temperature (°C)	Resistance (kΩ)
-25	144.266	15	16.079	55	2.841	95	0.708
-24	135.601	16	15.313	56	2.734	96	0.686
-23	127.507	17	14.588	57	2.632	97	0.666
-22	119.941	18	13.902	58	2.534	98	0.646
-21	112.867	19	13.251	59	2.44	99	0.627
-20	106.732	20	12.635	60	2.35	100	0.609
-19	100.552	21	12.05	61	2.264	101	0.591
-18	94.769	22	11.496	62	2.181	102	0.574
-17	89.353	23	10.971	63	2.102	103	0.558
-16	84.278	24	10.473	64	2.026	104	0.542
-15	79.521	25	10	65	1.953	105	0.527
-14	75.059	26	9.551	66	1.883		
-13	70.873	27	9.125	67	1.816		
-12	66.943	28	8.721	68	1.752		
-11	63.252	29	8.337	69	1.69		
-10	59.784	30	7.972	70	1.631		
-9	56.524	31	7.625	71	1.574		
-8	53.458	32	7.296	72	1.519		
-7	50.575	33	6.982	73	1.466		
-6	47.862	34	6.684	74	1.416		
-5	45.308	35	6.401	75	1.367		
-4	42.903	36	6.131	76	1.321		
-3	40.638	37	5.874	77	1.276		
-2	38.504	38	5.63	78	1.233		
-1	36.492	39	5.397	79	1.191		
0	34.596	40	5.175	80	1.151		
1	32.807	41	4.964	81	1.113		
2	31.12	42	4.763	82	1.076		
3	29.528	43	4.571	83	1.041		
4	28.026	44	4.387	84	1.007		
5	26.608	45	4.213	85	0.974		
6	25.268	46	4.046	86	0.942		
7	24.003	47	3.887	87	0.912		
8	22.808	48	3.735	88	0.883		
9	21.678	49	3.59	89	0.855		
10	20.61	50	3.451	90	0.828		
11	19.601	51	3.318	91	0.802		
12	18.646	52	3.191	92	0.777		
13	17.743	53	3.069	93	0.753		
14	16.888	54	2.952	94	0.73		

Table 4-5.2: Compressor discharge pipe temperature sensor resistance characteristics

Temperature (°C)	Resistance (kΩ)	Temperature (°C)	Resistance (kΩ)	Temperature (°C)	Resistance (kΩ)	Temperature (°C)	Resistance (kΩ)
-20	542.7	20	68.66	60	13.59	100	3.702
-19	511.9	21	65.62	61	13.11	101	3.595
-18	483.0	22	62.73	62	12.65	102	3.492
-17	455.9	23	59.98	63	12.21	103	3.392
-16	430.5	24	57.37	64	11.79	104	3.296
-15	406.7	25	54.89	65	11.38	105	3.203
-14	384.3	26	52.53	66	10.99	106	3.113
-13	363.3	27	50.28	67	10.61	107	3.025
-12	343.6	28	48.14	68	10.25	108	2.941
-11	325.1	29	46.11	69	9.902	109	2.860
-10	307.7	30	44.17	70	9.569	110	2.781
-9	291.3	31	42.33	71	9.248	111	2.704
-8	275.9	32	40.57	72	8.940	112	2.630
-7	261.4	33	38.89	73	8.643	113	2.559
-6	247.8	34	37.30	74	8.358	114	2.489
-5	234.9	35	35.78	75	8.084	115	2.422
-4	222.8	36	34.32	76	7.820	116	2.357
-3	211.4	37	32.94	77	7.566	117	2.294
-2	200.7	38	31.62	78	7.321	118	2.233
-1	190.5	39	30.36	79	7.086	119	2.174
0	180.9	40	29.15	80	6.859	120	2.117
1	171.9	41	28.00	81	6.641	121	2.061
2	163.3	42	26.90	82	6.430	122	2.007
3	155.2	43	25.86	83	6.228	123	1.955
4	147.6	44	24.85	84	6.033	124	1.905
5	140.4	45	23.89	85	5.844	125	1.856
6	133.5	46	22.89	86	5.663	126	1.808
7	127.1	47	22.10	87	5.488	127	1.762
8	121.0	48	21.26	88	5.320	128	1.717
9	115.2	49	20.46	89	5.157	129	1.674
10	109.8	50	19.69	90	5.000	130	1.632
11	104.6	51	18.96	91	4.849		
12	99.69	52	18.26	92	4.703		
13	95.05	53	17.58	93	4.562		
14	90.66	54	16.94	94	4.426		
15	86.49	55	16.32	95	4.294		
16	82.54	56	15.73	96	4.167		
17	78.79	57	15.16	97	4.045		
18	75.24	58	14.62	98	3.927		
19	71.86	59	14.09	99	3.812		

OPTIMUS PRO Split

Table 4-5.3: Water side heat exchanger water inlet / outlet temperature sensor, final outlet water temperature sensor and DHW temperature sensor resistance characteristics

Temperature (°C)	Resistance (kΩ)	Temperature (°C)	Resistance (kΩ)	Temperature (°C)	Resistance (kΩ)	Temperature (°C)	Resistance (kΩ)
-30	867.29	10	98.227	50	17.600	90	4.4381
-29	815.80	11	93.634	51	16.943	91	4.3022
-28	767.68	12	89.278	52	16.315	92	4.1711
-27	722.68	13	85.146	53	15.713	93	4.0446
-26	680.54	14	81.225	54	15.136	94	3.9225
-25	641.07	15	77.504	55	14.583	95	3.8046
-24	604.08	16	73.972	56	14.054	96	3.6908
-23	569.39	17	70.619	57	13.546	97	3.5810
-22	536.85	18	67.434	58	13.059	98	3.4748
-21	506.33	19	64.409	59	12.592	99	3.3724
-20	477.69	20	61.535	60	12.144	100	3.2734
-19	450.81	21	58.804	61	11.715	101	3.1777
-18	425.59	22	56.209	62	11.302	102	3.0853
-17	401.91	23	53.742	63	10.906	103	2.9960
-16	379.69	24	51.396	64	10.526	104	2.9096
-15	358.83	25	49.165	65	10.161	105	2.8262
-14	339.24	26	47.043	66	9.8105		
-13	320.85	27	45.025	67	9.4736		
-12	303.56	28	43.104	68	9.1498		
-11	287.33	29	41.276	69	8.8387		
-10	272.06	30	39.535	70	8.5396		
-9	257.71	31	37.878	71	8.2520		
-8	244.21	32	36.299	72	7.9755		
-7	231.51	33	34.796	73	7.7094		
-6	219.55	34	33.363	74	7.4536		
-5	208.28	35	31.977	75	7.2073		
-4	197.67	36	30.695	76	6.9704		
-3	187.66	37	29.453	77	6.7423		
-2	178.22	38	28.269	78	6.5228		
-1	168.31	39	27.139	79	6.3114		
0	160.90	40	26.061	80	6.1078		
1	152.96	41	25.031	81	5.9117		
2	145.45	42	24.048	82	5.7228		
3	138.35	43	23.109	83	5.5409		
4	131.64	44	22.212	84	5.3655		
5	125.28	45	21.355	85	5.1965		
6	119.27	46	20.536	86	5.0336		
7	113.58	47	19.752	87	4.8765		
8	108.18	48	19.003	88	4.7251		
9	103.07	49	18.286	89	4.5790		

